

SECTION D

REAR SUSPENSION

<u>Section</u>	<u>Description</u>	<u>Page</u>
D.1.	General description	3.
D.2.	Wishbones	3.
D.3.	Damper and spring	3.
D.4.	Resilient mountings	7.
D.5.	Suspension securing nuts	7.
D.6.	Bump limiting spacer	7.
	Hubs (see Section 'G')	
	Rotoflex couplings (see Section 'R')	
	Drive shafts (see Section 'R')	
	Setting-up suspension (see Section 'C')	

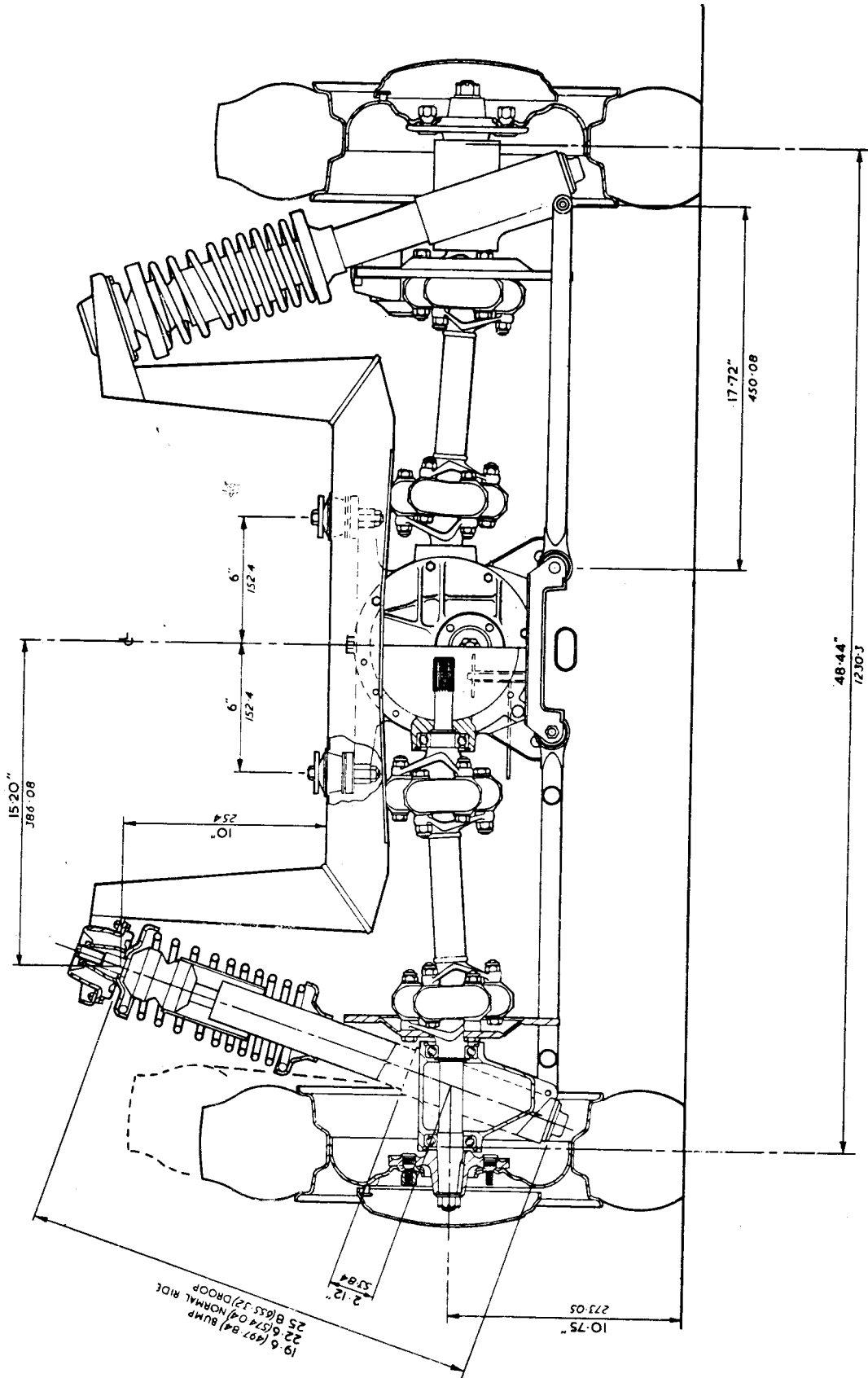

36-D1

Fig. 1. GENERAL ARRANGEMENT OF REAR SUSPENSION

D.1. - GENERAL DESCRIPTION

The rear suspension is of the fully independent Chapman strut type, incorporating coil springs and dampers. Wide-based lower wishbones are used which provide both lateral and longitudinal location of the rear bearing housing.

The rear bearing housing carries both the outboard drive shafts (and subsequently the wheels) and the lower end of the damper unit. The upper end of the damper unit is secured to the chassis by special 'Lotocone' flexible mountings.

D.2. - WISHBONESTo Remove

1. Remove the road wheels (see Section 'G').
2. Place a screw-type jack securely below the bearing housing and raise just sufficient to take the weight of the suspension.
3. Release the bolts securing the outer ends of the wishbones to the bearing housing. Push the wishbone down clear of the housing, then release bolts securing the inner ends of the wishbone to the chassis. Note that the bolts are fitted with their heads towards each other (i.e. from the inner faces).
4. Remove the wishbone from the car. If the wishbone is damaged in any way, it should be replaced by a new part. The application of heat to assist straightening will cause the metal to stretch, which will ultimately affect rear suspension geometry when rebuilt.

To Replace

1. If the bushes require replacing, these can be removed and replaced with the aid of a suitable press and pilot tool; the pilot tool is inserted through the hole in the bush, while its periphery should be of a size to bear on the outer metal sleeve of the bush.
2. Replacing the wishbone is a reversal of the removal procedure. Note which way the bolts are fitted (see paragraph '3' under 'To Remove'). Tighten all bolts to the torque loading given in 'Technical Data'.

D.3. - DAMPER AND SPRINGTo Remove

1. If either the damper or spring requires replacing, then the whole assembly of damper, spring and bearing housing must be removed.
2. Remove the road wheel (see Section 'G').

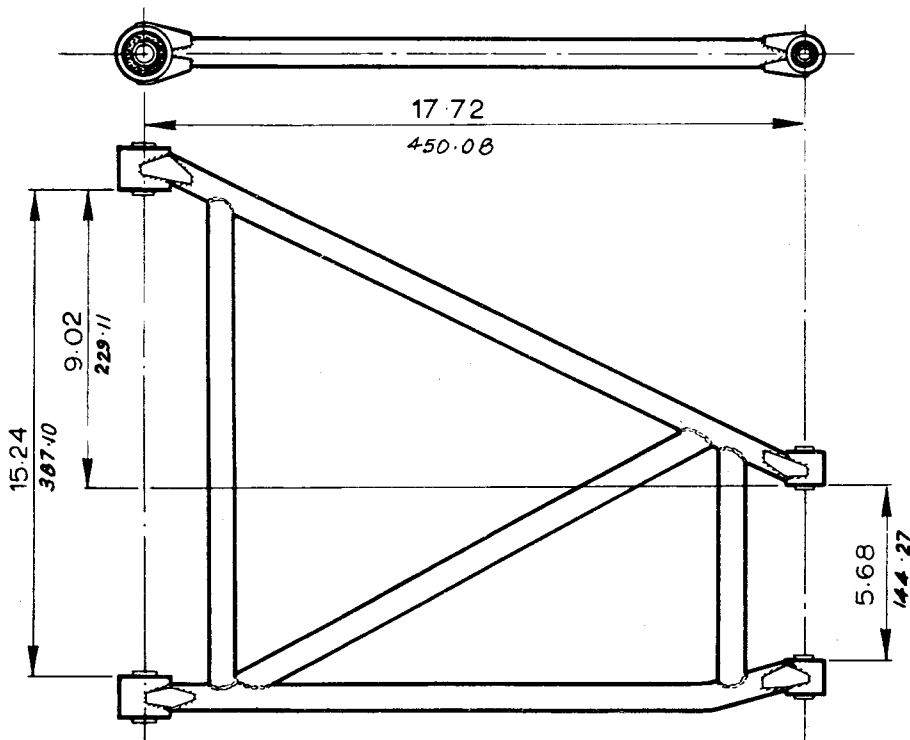
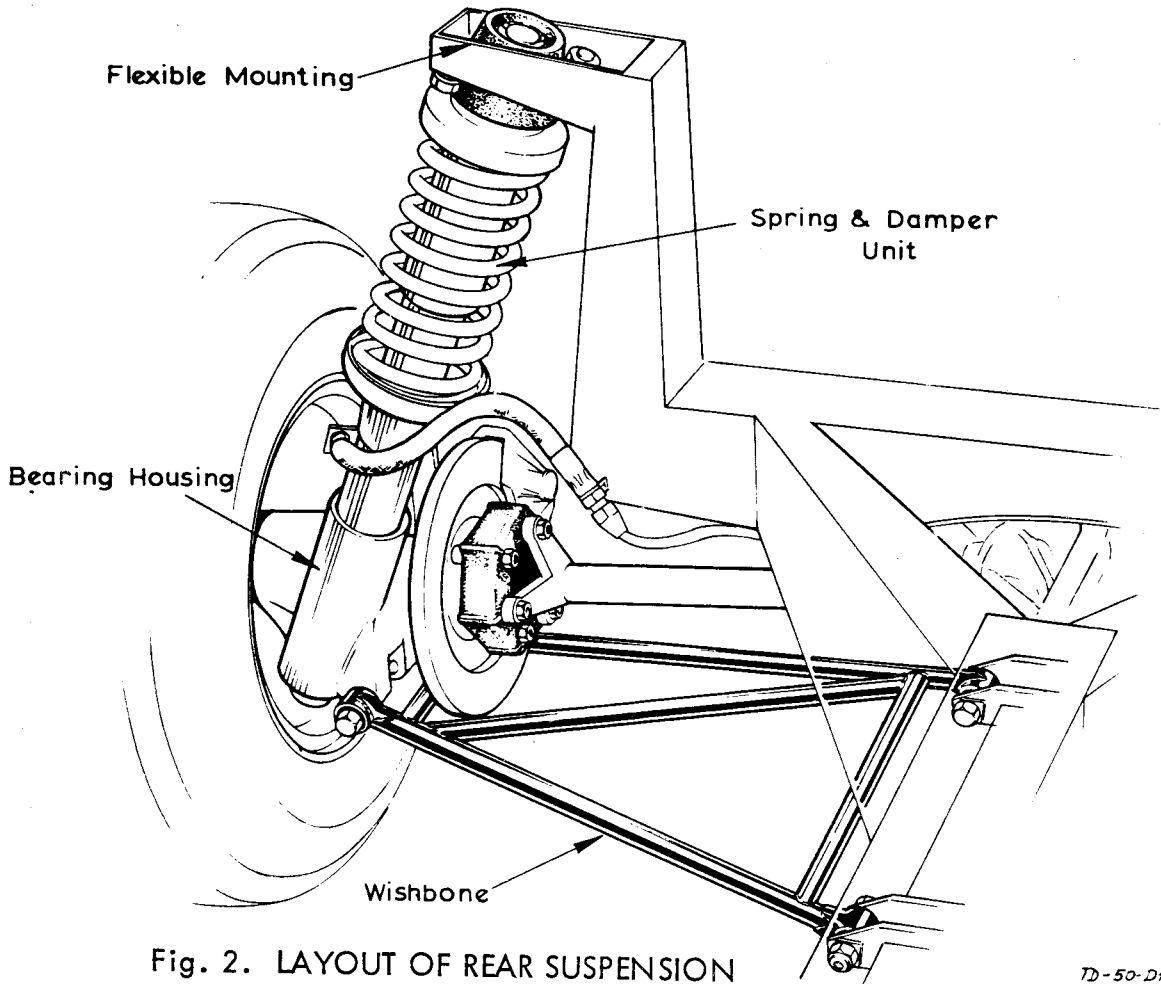

3. Place a screw-type jack securely below the bearing housing and raise just enough to take the weight of the suspension.
4. Remove upper dirt shield (if fitted), brake caliper and brake disc (see Section 'J').
5. Remove the bolts securing the outer end of the wishbone to the bearing housing and push wishbone down clear of the housing.
6. Remove outboard drive shaft (see Section 'G').
7. Remove the rear parcel tray (see Section 'B') then remove grommet concealing upper fixing of damper.
8. Release split pin locking the castellated nut and remove nut. Lower jack slowly as the spring is now free. Lift off spring abutment, bump stop and spring. Remove damper and bearing housing assembly to a bench.

To Replace

1. If it is desired to fit new dampers, Lotus Cars (Service) Limited recommend that both the damper and housing are replaced as an assembly. The housing bearings removal and replacement procedure is given in Section 'G' (Hubs, Wheels and Tyres). As an alternative to replacing both the damper and housing it is permissible to renew the working parts of the damper units.

These are obtainable from:-

Armstrong Patents Co.Ltd.,
Eastgate, Beverley, Yorks.

When re-assembling the damper unit, ensure that only the specified fluid is used.

Total quantity must be 380 c.c.

2. Clamp the spring with proprietary spring compressing clamps, place spring in position on the damper followed by the bump stop and the spring abutment. Note that the hole in the spring abutment is 'D' shaped, so too is the damper spindle; the holes should of course line up.
3. Insert a piece of wire through the split pin hole in the top of the damper spindle to guide the spindle through the hole in the resilient mounting. Push assembly into its location in the body with the aid of a jack, remove the wire from the damper spindle and replace castellated nut. Do not fully tighten nut at this stage.
4. Replace outboard drive shaft and brake disc.
5. Replace bolts securing outer end of wishbone to bearing housing.
6. Replace brake caliper and upper brake dirt shield.

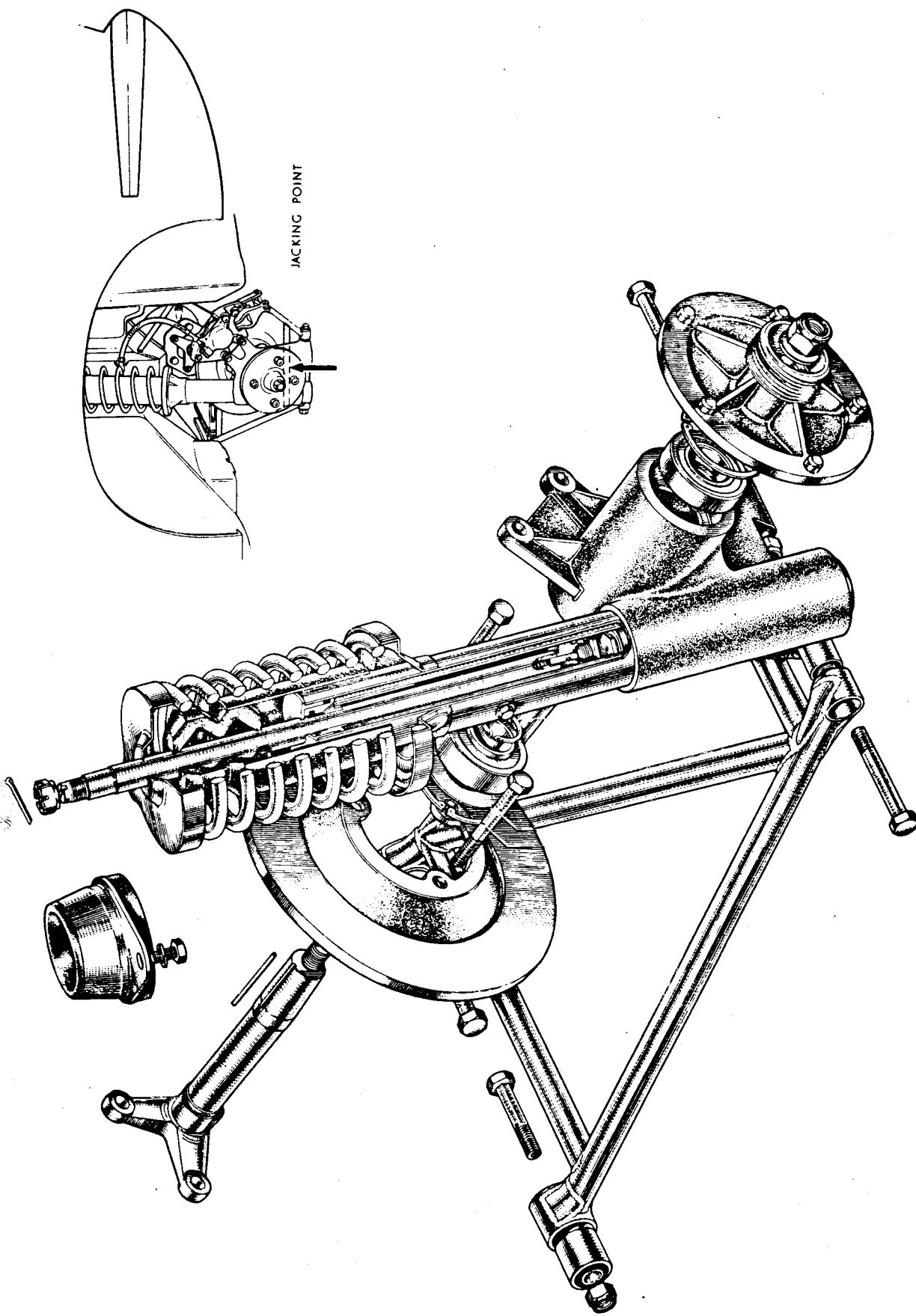

7D-50-23

Fig. 4. REAR SUSPENSION COMPONENTS

7. Replace the road wheel.
8. Set up suspension as given in Section 'C' (Front Suspension) tightening all suspension securing bolts to the torque loadings given in 'Technical Data'.
9. Replace grommet concealing upper damper fixings, finally replacing rear parcel tray.

D.4. - RESILIENT MOUNTINGS

The resilient mounting ('Lotocone') can only be removed after the damper and spring (Section 'D.3.') have been removed. Two setscrews with spring washers secure each mounting.

D.5. - SUSPENSION SECURING NUTS

Commencing at Chassis No.8797 all suspension securing nuts, with the exception of the castellated type, have been changed from 'Stover' type to 'Nyloc' type.

It is important to note that where nuts are tightened, then loosened, again tightened (as when setting-up the suspension), this process can with a 'Stover' nut, strip the threads from the bolt, the nut when being retightened having a tendency to cut its own thread.

When a 'Stover' nut is removed for replacing with a 'Nyloc' nut, the bolt also **MUST BE REPLACED.**

D.6. - BUMP LIMITING SPACER

Bump limiting spacers for fitting to the tops of the rear dampers to eliminate the possibility of 'grounding' when the car is used on rough terrain or carries an excessive load in the boot (trunk) are available through the Parts Division of Lotus Cars (Service) Limited.

The bump limiting spacers (Part No. 36 D 154) can be fitted to earlier cars in the following manner:-

1. Carry out the procedure given in Section 'D.3.' for removing the damper, but do not fully remove the damper.
2. Fit the spacer over the damper spindle, spigot end first, so that the spigot end fits over the top of the damper. Lightly tap the spacer with a hammer until it 'nips' the top of the damper.
3. Reverse the dismantling procedure for rebuilding the suspension.