

SECTION G

HUBS, WHEELS AND TYRES

<u>Section</u>	<u>Description</u>	<u>Page</u>
G.1.	General description	3.
G.2.	Front hubs - adjust	3.
G.3.	Front hubs - remove and replace	5.
G.4.	Rear hubs & outboard drive shafts - remove and replace	5.
G.5.	Rear hub bearings	7.
G.6.	Wheel drive pegs	7.
G.7.	Wheel studs	7.
G.8.	Wheels	8.
G.9.	Tyres	9.

ILLUSTRATIONS

<u>Fig. No.</u>	<u>Description</u>	<u>Page</u>
1.	Cross section of front hub	4.
2.	Adjusting front hub	4.
3.	Using the jack	6.
4.	Cross section of rear hub	6.

G.1. - GENERAL DESCRIPTION

'Knock-on' centre lock, or 'Bolt-on' wheels, of pressed steel construction (depending on model) are fitted to all models. The spare wheel is located in the luggage compartment below the floor on the left-hand side and is retained by a clamp and bolt.

When 'Knock-on' centre lock wheels are fitted, it is essential that the correct nuts be used with the appropriate wheels.

Radial ply tyres (with inner tubes where applicable) of Firestone, Goodyear or Dunlop manufacture have been fitted as original equipment depending on their availability. Tyre pressures should be maintained at the pressures given in 'Technical Data' and should be checked every 1,000 miles (1,600 km.).

The front hubs are mounted on two taper roller bearings and are designed to run with a specified end float (see 'Technical Data'). Overtightening will destroy the bearings.

The rear hub bearings consist of ball races pressed into the bearing housing and located by circlips.

G.2. - FRONT HUBS

Adjust

1. Loosen the road wheel securing nut.
2. Apply the handbrake and raise the front of the car on a suitable jack. Place chassis stands in position then remove jack.
3. Remove the wheel securing nut(s) and take off wheel.
4. Extract the split pin locking the hub securing nut and discard.
5. Mount a dial gauge in such a position that its plunger is against the front face of the hub. Tighten the securing nut sufficiently to give an indicated end float (see 'Technical Data'), back off the nut one flat (60°), then insert a new split pin to lock.
6. Repack hub with grease (see Section 'O'), working the grease well past the large washer below the securing nut. Only HALF FILL THE HUB to allow for expansion.
7. Replace the wheel, which must be assembled DRY. Do NOT grease or oil the threads. With centre lock wheels, ensure that the drive pegs are fully located BEFORE fitting wheel nuts.
8. Repeat above procedure for opposite wheel.

IC-50-C1.

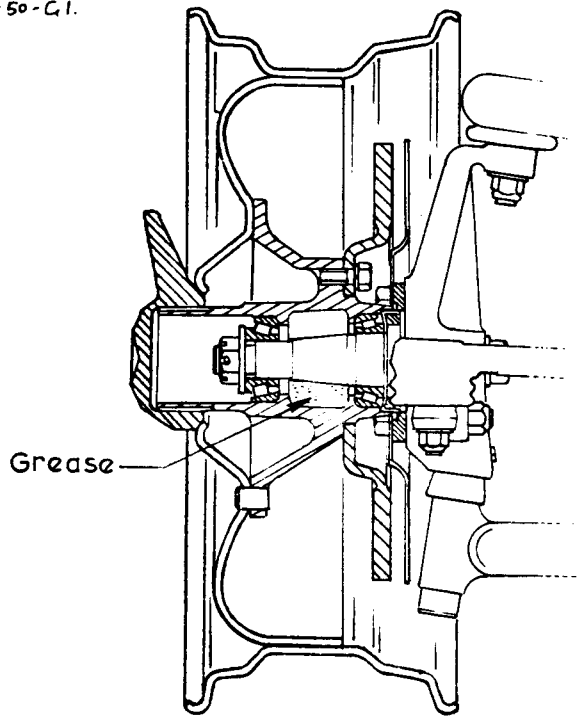

Fig. 1. CROSS SECTION OF FRONT HUB ('KNOCK-ON' WHEEL)

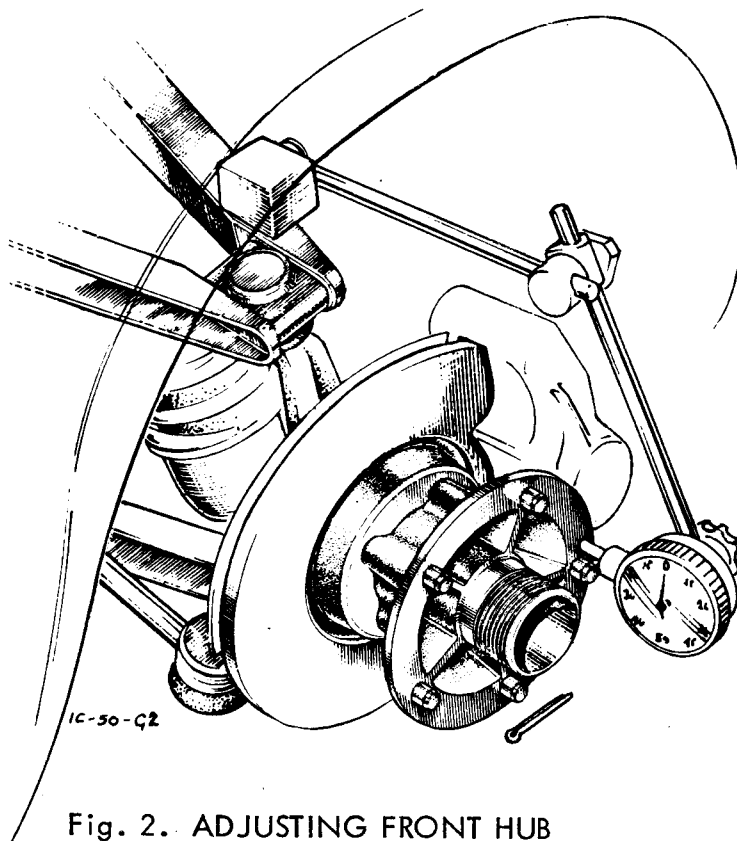

Fig. 2. ADJUSTING FRONT HUB ('KNOCK-ON' WHEEL)

G.3. - FRONT HUBS

IMPORTANT - 'Knock-on' centre lock wheels:

Hubs with RIGHT-HAND threads on RIGHT-HAND side (coloured GREEN),
hubs with LEFT-HAND threads on LEFT-HAND side (coloured RED).

To Remove

1. Remove the road wheel (Section 'G.2').
2. Break the fluid supply to the front caliper at its connection. Fit plug to pipe to avoid ingress of dirt.
3. Detach the brake caliper (see Section 'J').
4. Remove the split pin locking the securing nut and discard. Remove nut and washer.
5. From the rear of the brake disc, remove the bolts which retain both disc and hub. Pull off hub.

To Replace

1. Clean the mating faces of the hub and disc. These must be scrupulously clean if disc run-out is to be avoided.
2. Replace the bearings as necessary.
3. Fit the hub and disc assembly, tightening the securing bolts to the torque loading given in 'Technical Data'. Secure the hub with its nut and split pin repacking with grease and adjusting end-float (Section 'G.2').
4. Refit the caliper. Remove plug from pipe end and refit pipe to caliper. Tighten pipe nut to the torque loading given in 'Technical Data'. Bleed the brakes (see Section 'J').
5. Replace the road wheels and lower car to ground after removing chassis stands.

G.4. - REAR HUBS AND OUTBOARD DRIVE SHAFTS

IMPORTANT - 'Knock-on' centre lock wheels:

Hubs with RIGHT-HAND thread on RIGHT-HAND side (coloured GREEN),
LEFT-HAND thread on LEFT-HAND side (coloured RED).

No adjustment is provided on the rear hub bearings, maintenance therefore being limited to fitting new bearings.

To Remove

1. Loosen the road wheel securing nut.
2. Raise the rear of the car and support with chassis stands, then remove jack.
3. Remove the wheel securing nut and take off wheel. Remove the hub securing

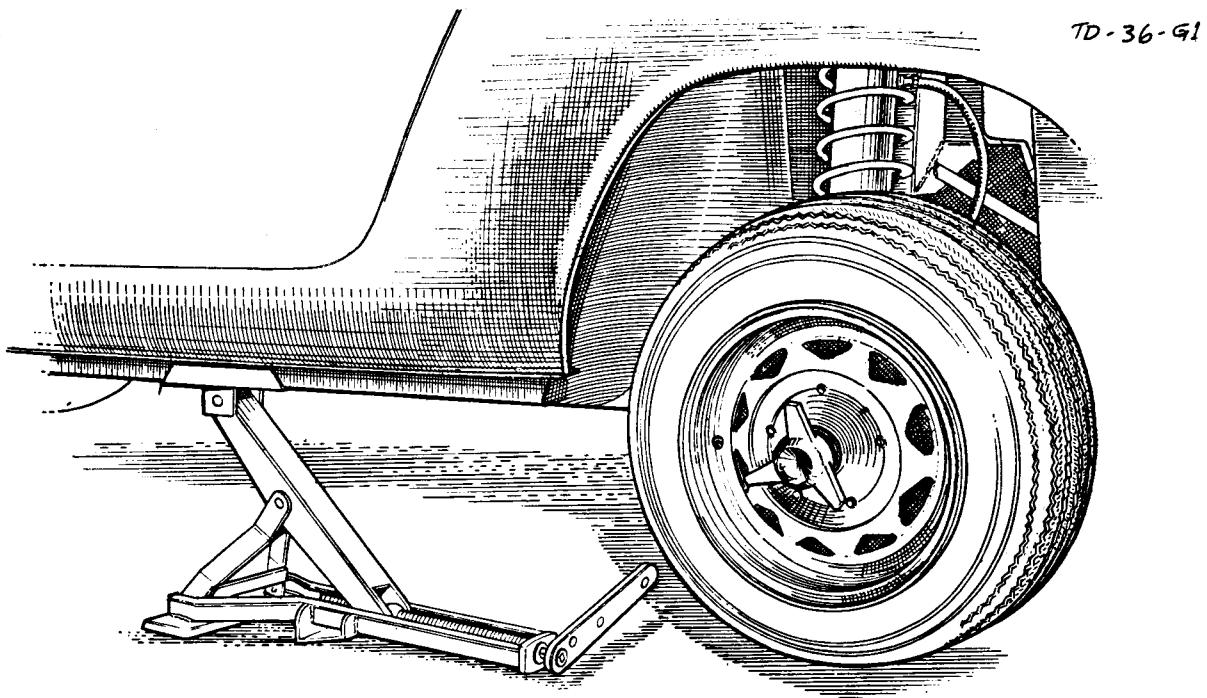

Fig. 3. USING THE JACK

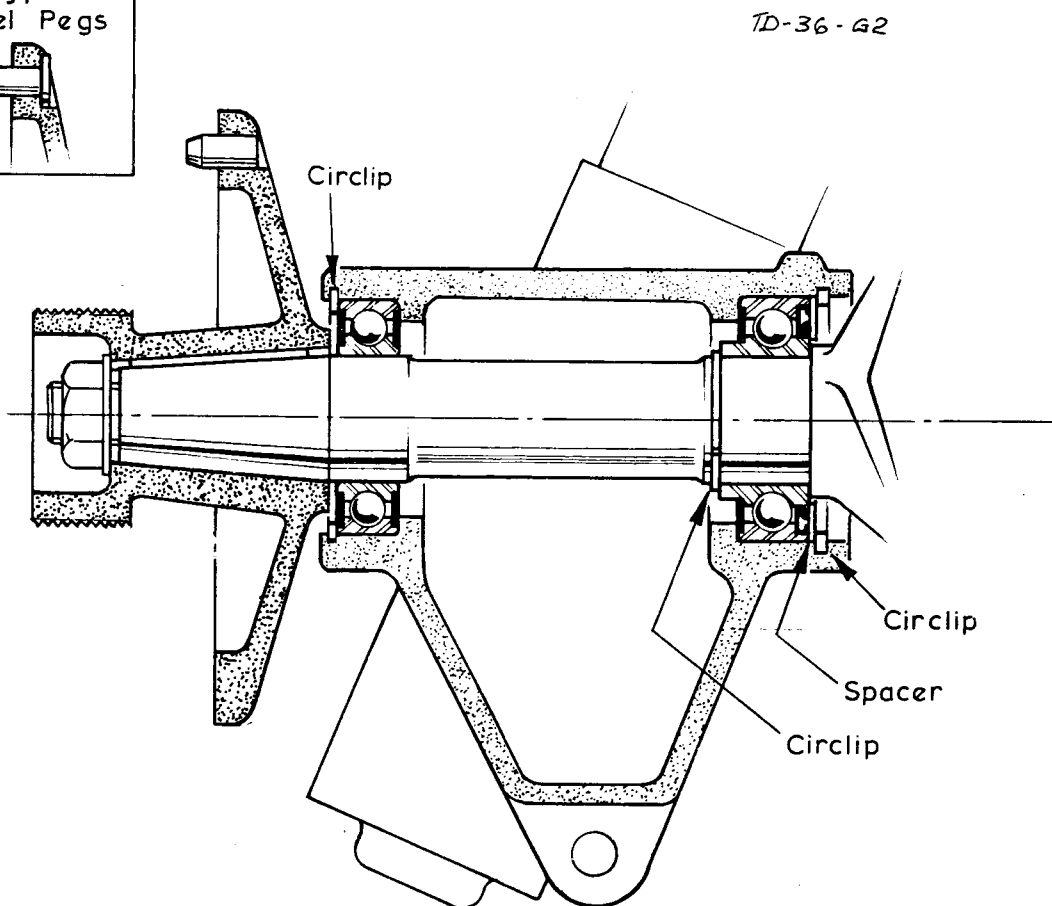
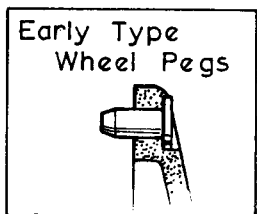

Fig. 4. CROSS SECTION OF REAR HUB, 'KNOCK-ON' WHEEL

nut with its washer.

4. Using a suitable extractor, pull off the hub. For 'bolt-on' wheels use extractor S356 for 'knock-on' wheels use adaptors X036 T 0285Z L/H and X036 T 0286Z R/H in conjunction with the extractor. This extractor is available from V.L.Churchill & Co. Ltd., London Road, Daventry, Northamptonshire, England.
5. To remove the bearings it is first necessary to release the brake caliper from the bearing housing followed by the three bolts securing the flexible coupling and brake disc to the outboard drive shaft. Removal of the two bolts securing the wishbone to the bearing housing will improve access to release the inner wheel bearing circlip. Push the drive shaft and inner bearing from the housing. Remove the inner bearing locating circlips from the shaft and press the bearing off the shaft.

To Replace

1. When replacing the bearings, which is a reversal of the removal procedure, it is necessary to trim flush the surplus seal which stands proud of the outer race on the inner bearing (nearest to the drive flange coupling), so that the spacer and retaining circlip may be fitted correctly.
2. Whilst the bearings are of the sealed type, it is recommended that grease be applied to the internal surfaces of the bearing housing to assist in preventing corrosion. Locate the outboard drive shaft.
3. Lining-up the keyway, push on the rear hub and secure with nut (Part No. A036 D 6019) and a washer. Tighten nut to the torque given in 'Technical Data'.
4. Replace the road wheel and lower car to ground after removing chassis stands.

G.5. - REAR HUB BEARINGS

Commencing at Chassis No. 45/7743 and 36/7762, modified INNER bearings (36 D 6003) were fitted to overcome possible failure due to ingress of dirt and/or moisture.

Modified OUTER bearings (36 D 6017) have been fitted since Chassis No. 9095. These bearings will give a longer life expectancy than those previously specified.

G.6. - WHEEL DRIVE PEGS

If the occasion arises where it is necessary to change the wheel drive pegs, it is pointed out that these have an interference fit in the hubs. When renewing therefore, heat the hub sufficient to enable the new pegs to be driven in with moderate force without impairing the interference fit.

G.7. - WHEEL STUDS

If the occasion arises where it is necessary to renew the wheel studs, it is pointed out that these have an interference fit in the hub and must also be assembled with Loctite.

When renewing, heat the hub sufficient to enable the new studs to be driven in with moderate force without impairing the interference fit.

G.8. - WHEELS

S.M.M.T. (Society of Motor Manufacturers and Traders) standard tolerances of the wheel only are:-

a. Wobble

The lateral variation measured on the vertical inside face of a flange must NOT EXCEED .05 in. (1.27 mm.)

b. Lift

The difference between the high and low points of a rotating wheel measured at any location on either bead seat must NOT EXCEED .05 in. (1.27 mm.).

Lateral and radial inaccuracies outside these limits contribute respectively to dynamic and static unbalance.

Severe eccentricity intermittently increases the load on the tyre and results in irregular wear. Static and dynamic balancing will NOT rectify this condition.

Wheel Alignment

Settings for front and rear wheel alignment are given in 'Technical Data'.

Excessive misalignment caused by kerb impact or other accidental damage will result in severe tyre wear and faulty steering.

Steel Wheels Maintenance

Ensure that the bead seats and flange faces are kept free from rust and dirt and that wheels having damaged or elongated drive peg or stud holes are replaced.

Locally damaged flanges may be corrected by careful hammering, but a buckled wheel, i.e. one which no longer conforms to the tolerances quoted, must be replaced.

Wheel Removal

1. Slacken the nut(s) of the desired wheel using either the special mallet (for 'ear-type' nuts), spanner (for 'hexagon type' nuts), or wheelbrace (for 'bolt-on' wheels), supplied with the car. Centre lock wheel nuts on LEFT-HAND side of car are released in a CLOCKWISE direction, while nuts on RIGHT-HAND side are released in an ANTI (COUNTER) - CLOCKWISE direction. On cars with 'bolt-on' wheels, all wheel nuts are removed in an ANTI (COUNTER) - CLOCKWISE direction.
When replacing nuts, ensure their rounded ends are facing the wheel.
2. Raise the vehicle and fully release the wheel nut. Pull off wheel.
3. When replacing the wheel, ensure that it is fully seated on the hub and with centre

lock wheels on the drive pegs BEFORE replacing the nut. Do NOT grease or oil the threads on hubs, studs or wheel nuts. Just clean.

Wheel Nuts

Check security of all types of wheel nuts at between 5 and 10 miles (8 and 16 km.) after initial fitting, and thereafter every 1,000 miles (1,600 km.) or weekly, whichever occurs first.

G.9. - TYRES

Tyre Care

Check at intervals of every 1,000 miles (1,600 km.) that the tyre pressures are correct.

Ensure that the tyres are cold when checking the pressures. Never bleed air out of a warm tyre in order to achieve the recommended pressure, since when the tyre cools it will be under-inflated.

If oil or grease have been in contact with a tyre wipe the affected area with a cloth lightly moistened with petrol or trichloroethylene.

New Tyres

When new tyres are required it is essential to fit the same type as those remaining on the vehicle. The characteristics of tyres vary considerably, therefore, if tyres are changed for those of a different type, then it is imperative that all tyres, including the spare, are changed at the same time.

If trouble is experienced with replacement tyres, reference should be made to the manufacturers concerned.

Inflation Pressures

Severe and persistent under-inflation produces unmistakable evidence on the tread. It also causes structural failure due to excessive friction and temperature within the casing.

Pressures higher than those recommended reduce tread life by concentrating the load on a small tread area. Excessive pressures overstrain the casing, cause rapid wear and make the tyres more susceptible to impact fractures and cuts.

Effect of Temperature

Air expands with heating and tyre pressures increase as the tyres warm up. Pressures increase more in hot weather than in cold weather and as a result of high speed.

Pressure in warm tyres should not be reduced to standard pressure for cold tyres. 'Bleeding' the tyres increases their deflections and causes their temperatures to climb still

higher. The tyres will also be under-inflated when they have cooled.

The rate of tread wear may be twice as fast at 50 m.p.h. (80 k.p.h.) as at 30 m.p.h. (48 k.p.h.).

High speed causes increased temperatures due to more deflections per minute and a faster rate of deflection and recovery. The resistance of the tread to abrasion decreases with increased tyre temperature.

Camber, Castor and King Pin Inclination (see also Section 'C').

These angles normally require no attention unless they have been disturbed by a severe impact or abnormal wear of front end bearings. It is always advisable to check them if steering irregularities develop.

Wheel camber, usually combined with road camber, causes a wheel to try to turn in the direction of lean, due to one side of the tread attempting to make more revolutions per mile than the other side. The resulting increased tread shuffle on the road and the off-centre tyre loading tend to cause rapid and one-sided wear. Unequal cambers introduce unbalanced forces which try to steer the car one way or the other. This must be countered by steering in the opposite direction which increases tread wear.

Castor and king pin inclination by themselves have no direct bearing on tyre wear but their measurement is often useful for providing a general indication of the condition of the front end geometry and suspension.

Braking

Irregular braking torque produces excessive local tread wear generally caused by eccentric brake discs or the use of incorrect pad lining materials. 'Spotty' wear may be due to a variety of faults, and if present, the following items should be checked:-

1. Inflation pressure.
2. Wheel balance.
3. Steering swivels for wear.
4. Wheel hub bearing condition and adjustment.
5. Wheel alignment.

Wheel Alignment and Road Camber

Fins and feathers on the tread surface are due to severe wheel misalignment. The condition takes the form of a sharp 'fin' on the edge of each pattern rib and the position of this indicates the direction of misalignment.

Excessive TOE-IN will cause fins on the INBOARD edges of the pattern rib.

Excessive TOE-OUT will cause fins on the OUTBOARD edges of the pattern rib.