

SECTION O

LUBRICATION AND MAINTENANCE

<u>Section</u>	<u>Description</u>	<u>Page</u>
O.1	Maintenance - general	3
O.2	Free service	3
O.3	'A' service	4
O.4	'B' service	6
O.5	'C' service	6
O.6	Lubrication - general	8
O.7	Lubrication intervals	8
O.8	Recommended lubricants	13
O.9	Approved anti-freeze solutions	15
O.10	Exhaust emission engines	16
	<u>Additional Information</u>	
O.11	Air horns lubrication	17

ILLUSTRATIONS

<u>Fig. No.</u>	<u>Description</u>	<u>Page</u>
1.	Dip stick	7.
2.	Sump drain plug	7.
3.	Oil filter assembly	7.
4.	Oil filler & drain plugs	9.
5.	Filler/level plug	9.
6.	Steering unit plug	9.
7.	Steering swivel plug	11.
8.	Damper reservoir (Zenith-Stromberg)	11.
9.	Position of fluid reservoirs	11.
10.	Lubrication diagram	14.

O.1. - MAINTENANCE - GENERAL

In order to maintain the vehicle in an efficient, safe and economical running condition, regular and thorough servicing is essential. The Lotus voucher scheme has been established to provide this service and covers both lubrication and regular mechanical maintenance using recommendations laid down by the technical staff of Lotus Cars Limited.

The voucher service commences with a FREE 'After Sales Service'. Further vouchers are included in the Service Voucher Book to cover lubrication and maintenance at intervals of every 3,000 miles (5,000 km.) up to and including 60,000 miles (100,000 km.)

It is very important that the vouchers should be used in the correct sequence and at the appropriate mileage. If any particular service is accidentally omitted, the remaining sequence of operations will be affected.

It must be understood that all oils and materials used in these services will be charged for in addition to the charges for the services.

In line with our policy of continuous product improvement, Lotus Dealers are informed of all technical development or improvements that have been made to subsequent vehicles, which could improve the performance of all vehicles.

Lotus Cars Limited reserve the right to change prices, specifications and equipment at any time without notice.

O.2 - FREE SERVICE (500 miles; 800 km.)

Free After Sales Service

1. LUBRICATION

Drain engine and gearbox and refill with new oil. Drain, flush and refill rear axle with new oil. Grease or oil all lubrication points, including lower steering swivels. Lubricate throttle linkages and carburettor controls. Fit new engine oil filter.

2. ENGINE

Check valve clearances. Check throttle openings on carburettors and re-set if necessary. Check carburettor mountings for correct vertical movement. Check cylinder head retaining bolts for correct torque loadings. Examine water hose connections and radiator coolant level. Check fan belt tension.

level. Check fan belt tension. Check security of manifolds, exhaust system, engine mountings, distributor and generator mounting bolts. Check timing chain tensioner adjustment. Check security of carburetters ram pipes retaining nuts.

3. IGNITION

Check distributor contact breaker gap and adjust if necessary. Check sparking plug gaps and adjust if necessary.

4. BRAKES

Check brakes, system, operation and adjustment, including handbrake. Check brake fluid reservoir level and top up if necessary. If low, check for leaks. Check all brake pipes and hoses for security. Check, and tighten if necessary, brake caliper mountings.

5. CLUTCH

Check correct operation and free movement of clutch. Check clutch fluid reservoir level and top up if necessary. If low, check for leaks.

6. STEERING AND SUSPENSION

Check that all steering connections are secure. Check steering unit mountings for tightness. Check front wheel alignment. Check wishbone and damper connections on front and rear suspension units.

7. ELECTRICAL

Check operation and function of all electrical equipment. Check headlamp retracting mechanisms. Check electrolyte level of battery and top up if necessary. Check tightness of terminals.

8. WHEELS AND TYRES

Check all wheel nuts for tightness. Check all tyre pressures including spare.

9. BODY

Check body condition generally including door adjustment, boot lock, bonnet (hood) operation and all attachment points. Check seat sliding mechanisms. Check operation of screen washers.

10. GENERAL

Check propeller shaft universal joints for tightness. Check drive shaft rubber couplings for tightness. Check fuel pipe unions.

O.3. - 'A' SERVICE (every 3,000 miles; 5,000 km.)

1. LUBRICATION

Drain engine and refill with new oil. Grease or oil all lubrication points.

Lubricate accelerator linkage. Check and top up oil levels in gearbox and rear axle if necessary. Lubricate all doors, bonnet and boot locks, catches, hinges.

2. ENGINE

Check slow running adjustment. Check vertical movement of carburettors on manifold. Top up radiator coolant level if necessary. Make visual inspection of all water pipe connections, including heater pipes. Top up windscreen washer bottle. Check timing chain tensioner adjustment.

3. IGNITION

Check distributor contact breaker gap and adjust if necessary. Lubricate cam and weights

4. BRAKES

Check brakes, system and operation, including handbrake. Check foot pedal travel. Check condition of all pads and if down to 1/16 in. (1.6 mm.) replace pads. Check brake fluid reservoir level and top up if necessary. If low, check for leaks.

5. CLUTCH

Check clutch fluid reservoir level and top up if necessary. If low, check for leaks.

6. STEERING AND SUSPENSION

Check steering assembly for general condition. Check front wheel alignment and adjust if necessary.

7. ELECTRICAL

Check electrolyte level of battery. Clean battery posts and terminals and smear with silicone grease. Ensure tightness of terminals on replacement. Check operation of all circuits. Check headlamp focus.

8. WHEELS AND TYRES

Dynamically balance wheels and tyre assemblies. Check all tyre pressures including spare.

9. BODY

Check body condition generally including door adjustment, bonnet catches, boot lock and all body attachment points.

10. GENERAL

Check condition and tightness of engine mounting bolts, propeller and drive shafts retaining nuts and bolts, generator mounting bolts.

O.4. - 'B' SERVICE (every 6,000 miles; 10,000 km.)

'A' Service plus the following :-

1. LUBRICATION

Drain gearbox and refill with new oil. Check and top up oil level in rear axle if necessary. Fit new engine oil filter.

2. ENGINE

Check cylinder head bolts for correct torque loading. Clean petrol pump filter. Check fan belt tension and adjust if necessary. Check valve clearances and adjust if necessary.

3. IGNITION

Clean and adjust sparking plug points.

4. BRAKES

Renew brake servo unit air filter (where fitted)

5. CLUTCH

Check correct operation and free movement of clutch.

6. STEERING AND SUSPENSION

Check wishbones and shock absorber mountings on front and rear suspension. Check front hubs lubrication and repack with grease if necessary. Lubricate lower steering swivels.

7. ELECTRICAL

Check windscreen wiper operation and arc. Check function and operation of all circuits.

8. BODY

Check seat and window mechanisms for ease of functioning.

9. GENERAL

Check condition and tightness of brake caliper mounting bolts, steering unit mountings, exhaust manifolds, exhaust system and distributor mountings.

O.5. - 'C' SERVICE (every 12,000 miles; 20,000 km.)

'A' and 'B' Services, plus the following :-

1. LUBRICATION

Drain, flush and refill rear axle. Lubricate dynamo (generator) rear bearing. Top up carburettor damper reservoirs (Zenith - Stromberg).

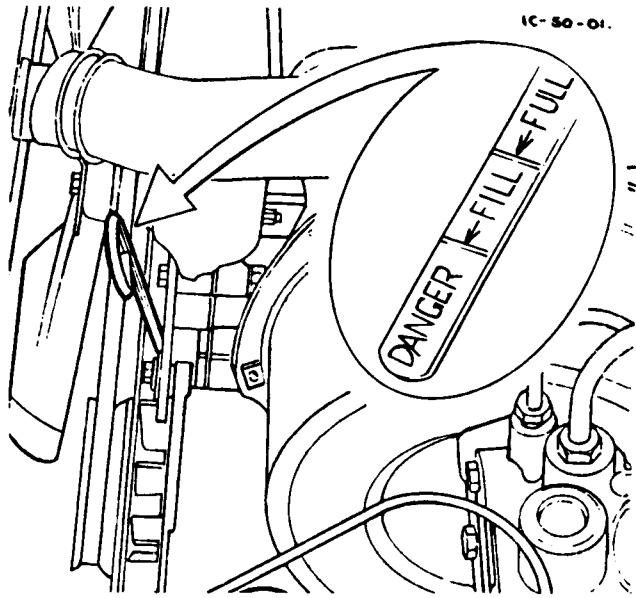

Fig. 1. DIP STICK

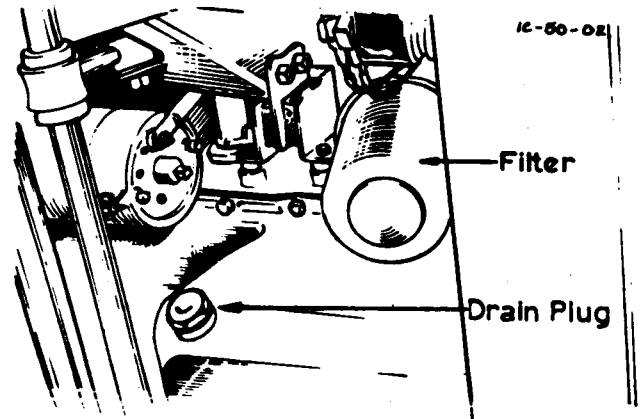

Fig. 2. SUMP DRAIN PLUG

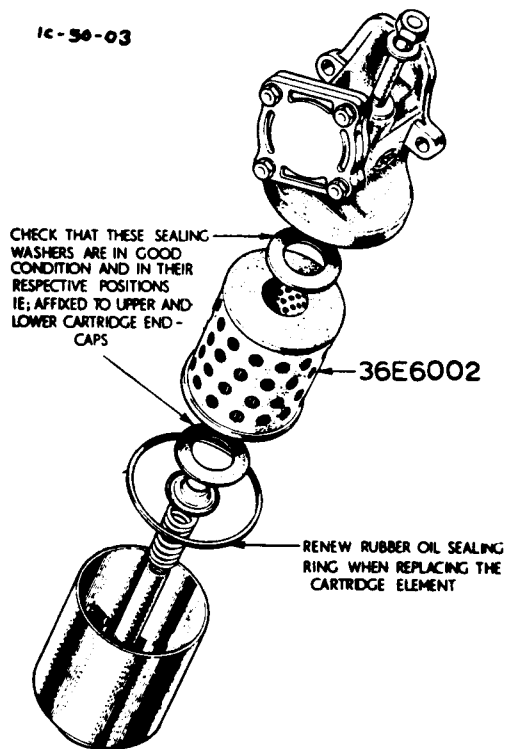

Fig. 3. OIL FILTER ASSEMBLY

2. ENGINE

Check security and condition of distributors, coil and starter motor. Fit new air cleaner element.

3. BRAKES

Check for wear on master cylinder linkage and pedal bearings.

4. CLUTCH

Check for wear on master cylinder linkage and pedal bearings.

5. STEERING AND SUSPENSION

Check all steering and suspension moving parts for wear. Lubricate steering unit.

6. ELECTRICAL

Check vacuum connections on headlamp mechanism.

O.6. - LUBRICATION - GENERAL

Conscientious and regular attention to the various lubrication points cannot be over emphasised. Correct lubrication with the recommended grades will ensure maximum performance and life from the components with efficiency and reliability in operation.

It is most important that the intervals shown under the 'A', and 'B' and 'C' Services are strictly adhered to.

O.7. - LUBRICATION INTERVALSENGINE

The correct level is to the 'FULL' mark on the dipstick, which is located to the left hand side of the timing cover. The oil filler cap is at the rear of the left hand side of the cam shaft cover. Inspect the oil level daily, topping-up if necessary to the correct level. DO NOT overfill. Replace the oil filler cap securely (double notch), otherwise an oil loss will occur and could result in a complete failure of the engine lubrication system.

Draining the Sump. - Draining the sump will be greatly facilitated if carried out when the car has just completed a run and the oil is warm, thus flowing more readily.

Allow to drain thoroughly, clean the drain plug and replace. The drain plug is located at the right hand rear of the sump.

NOTE: If the engine oil is renewed at the recommended intervals there is no necessity to use a flushing oil. The use of a flushing oil is NOT recommended because of the difficulty in draining it completely.

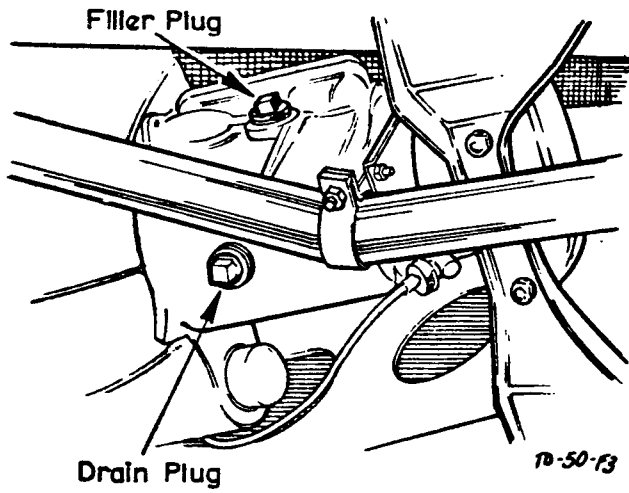

Fig. 4. OIL FILLER & DRAIN PLUGS

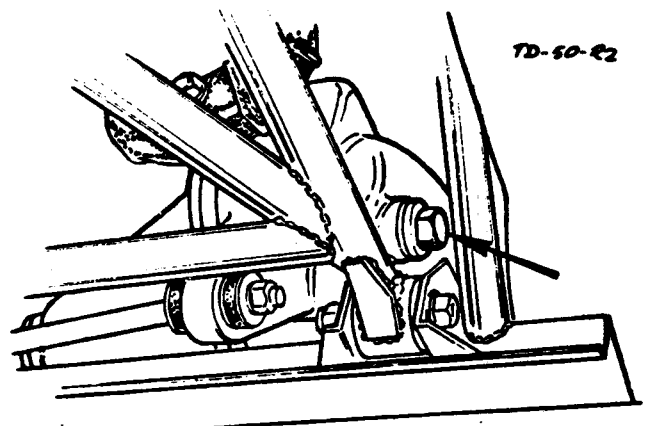

Fig. 5. FILLER/LEVEL PLUG

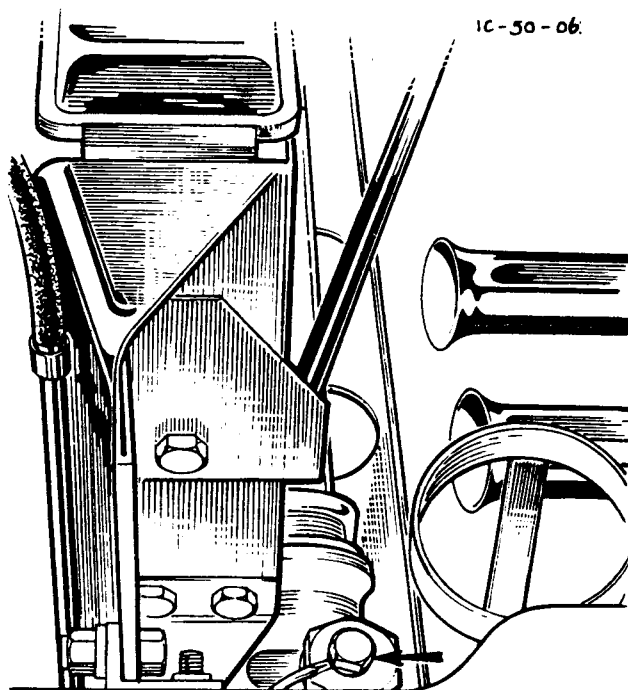

Fig. 6. STEERING UNIT PLUG

Oil Filter - It is recommended that the oil filter element be renewed at intervals of every 6,000 miles (10,000 km.).

To renew the filter element, release the central bolt retaining the filter body to the oil pump body, on the right-hand side of the engine. Thoroughly clean the inside of the filter body, fit new sealing rings and element, and refit to engine. Torque load the central retaining bolt to the loading given in 'Technical Data'. It is pointed out that it is false economy to fit a new oil filter alone; always refill engine with new oil, after draining the sump.

GEARBOX

A combined filler and level plug is fitted on the left-hand side of the gearbox, the drain plug being situated below the gearbox. The oil level should reach the bottom of the filler plug orifice and Extreme Pressure oil of the correct grade added if necessary. Gearbox lubricant should be drained at 6,000 miles (10,000 km.) intervals, preferably when the oil is warm after a run. Ensure that the drain plug is cleaned thoroughly before being replaced and tightened.

DIFFERENTIAL UNIT

The differential when new is filled with a special 'running-in' oil. The used lubricant must be drained, and the differential housing flushed out (with a good quality flushing oil, not paraffin) at 500 miles (800 km.) and subsequently every 12,000 miles (20,000 km.). Refill the axle with the specified lubricant, after ensuring that all flushing oil is removed.

The combined filler/level plug is located on the rear face of the differential housing, and the drain plug at the right-hand lower front.

STEERING UNIT

At intervals of every 12,000 miles (20,000 km.), remove the plug from the top of the unit and fit a screwed grease nipple. Apply the grease gun filled with one of the recommended greases (see Section 'O.8') and give FIVE STROKES ONLY; over-greasing can cause damage to the bellows. Remove the nipple and refit the plug.

LOWER STEERING SWIVELS

At intervals of every 6,000 miles (10,000 km.) remove the plugs and fit screwed grease nipples. Apply a grease gun filled with one of the recommended lubricants and pump the gun until oil exudes from the swivels. Remove the nipples and refit the plugs.

CARBURETTERS - ZENITH STROMBERG

At intervals of every 3,000 miles (5,000 km.) check the oil level in the carburetter

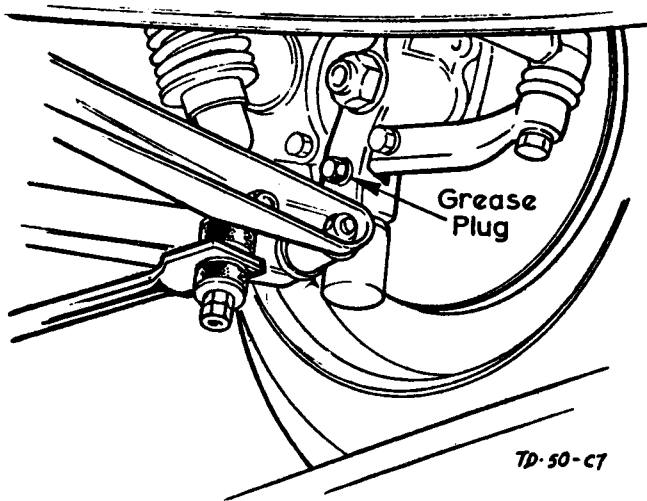

Fig. 7. STEERING SWIVEL PLUG

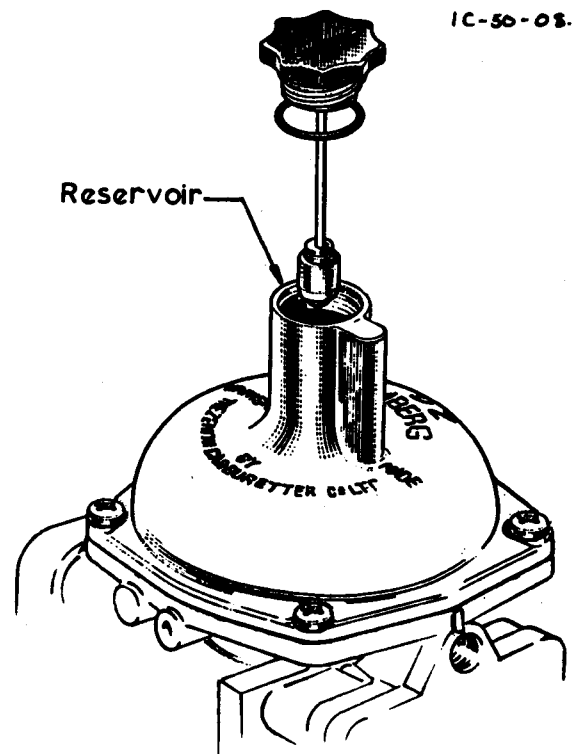

Fig. 8. DAMPER RESERVOIR
(ZENITH-STROMBERG)

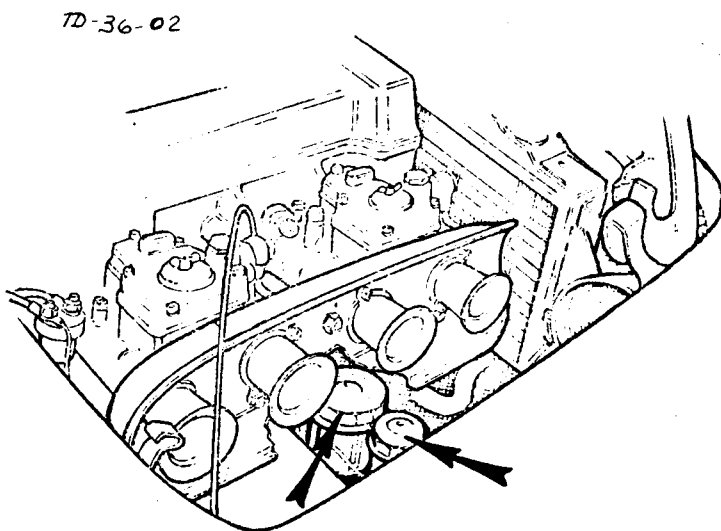

Fig. 9. POSITION OF FLUID RESERVOIRS

damper reservoirs, by releasing the black cap from the top of each carburetter and withdrawing the damper assembly. The oil level should be $\frac{1}{4}$ in. (6.35 mm.) from the top of the centre rod. When topping-up use the recommended engine oil. Replace the caps securely taking care not to overtighten as this will extrude the rubber sealing rings.

BRAKE AND CLUTCH FLUID RESERVOIRS

The brake and clutch fluid reservoirs are located at the rear end of the engine compartment, just forward of the main bulkhead, on the driving side.

Check fluid levels in the reservoirs at intervals of every 3,000 miles (5,000 km.) topping-up if necessary to within $\frac{1}{2}$ in. (12 mm.) of the top. Use only the specified fluid for topping-up.