

SECTION Q

CLUTCH

<u>Section</u>	<u>Description</u>	<u>Page</u>
Q.1.	General description	3.
Q.2.	Maintenance	3.
Q.3.	Clutch assembly	5.
Q.4.	Clutch driven plate	5.
Q.5.	Release bearing	7.
Q.6.	Hydraulic system	9.
Q.7.	Master cylinder	9.
Q.8.	Slave cylinder	10.
Q.9.	Clutch piping with fabricated exhaust manifold	11.

ILLUSTRATIONS

<u>Fig. No.</u>	<u>Description</u>	<u>Page</u>
1.	Clutch components	4.
2. (a & b)	Clutch engaged & dis-engaged	4.
3.	Clearance at release arm	6.
4.	Clutch fluid reservoir	6.
5.	Clutch disc location	6.
6.	Thrust bearing linkage to arm	6.
7.	Fitting clutch thrust bearing to carrier	8.
8.	Master cylinder components	8.
9.	Dismantling seals	8.
10.	Slave cylinder	8.

Q.1. - GENERAL DESCRIPTION

The clutch assembly comprises a diaphragm spring type pressure plate with a single dry driven plate. To ensure a smooth take up of the drive, the linings of the clutch driven plate are flexibly mounted and the hub is spring cushioned.

The clutch driven plate is free to slide along the splines of the gearbox mainshaft, the forward end of which forms a spigot, to fit into the clutch pilot bearing in the centre of the crankshaft. The clutch cover, diaphragm spring and pressure plate are serviced as an assembly.

The clutch release mechanism is hydraulically actuated by a pendant pedal connected by a push rod to the clutch master cylinder.

A flexible pipeline connects the clutch master cylinder with the clutch slave cylinder mounted on the clutch housing.

This method of clutch operation ensures smooth clutch engagement as relative movement between the engine and the clutch pedal is not transferred to the operating mechanism.

Pressure in the clutch slave cylinder operates an adjustable push rod, which, in turn, acts on the release arm end.

The diaphragm spring is pivoted on three shouldered pins and retained to these pins by two fulcrum rings. When the diaphragm's centre is moved towards the flywheel by the release bearing, the diaphragm's outer edge deflects towards the clutch housing causing the clutch to disengage.

The release bearing is retained to the clutch release arm fork by means of two single coil springs and a semi-circular link.

Q.2. - MAINTENANCE

The maintenance required for the clutch system is confined to topping-up the master cylinder and checking the clutch adjustment (see also Section 'O').

Clutch Adjustment

The clutch should be adjusted until the clearance between the slave cylinder push rod adjusting nut and the release arm is .08 in. (2.03 mm.), after the pedal has returned the full length of its travel.

To carry out this adjustment, disconnect the retracting spring, release the locknut and, holding the push rod by the flats provided, turn the adjusting nut until the correct clearance is obtained between the end of the release arm and the nut.

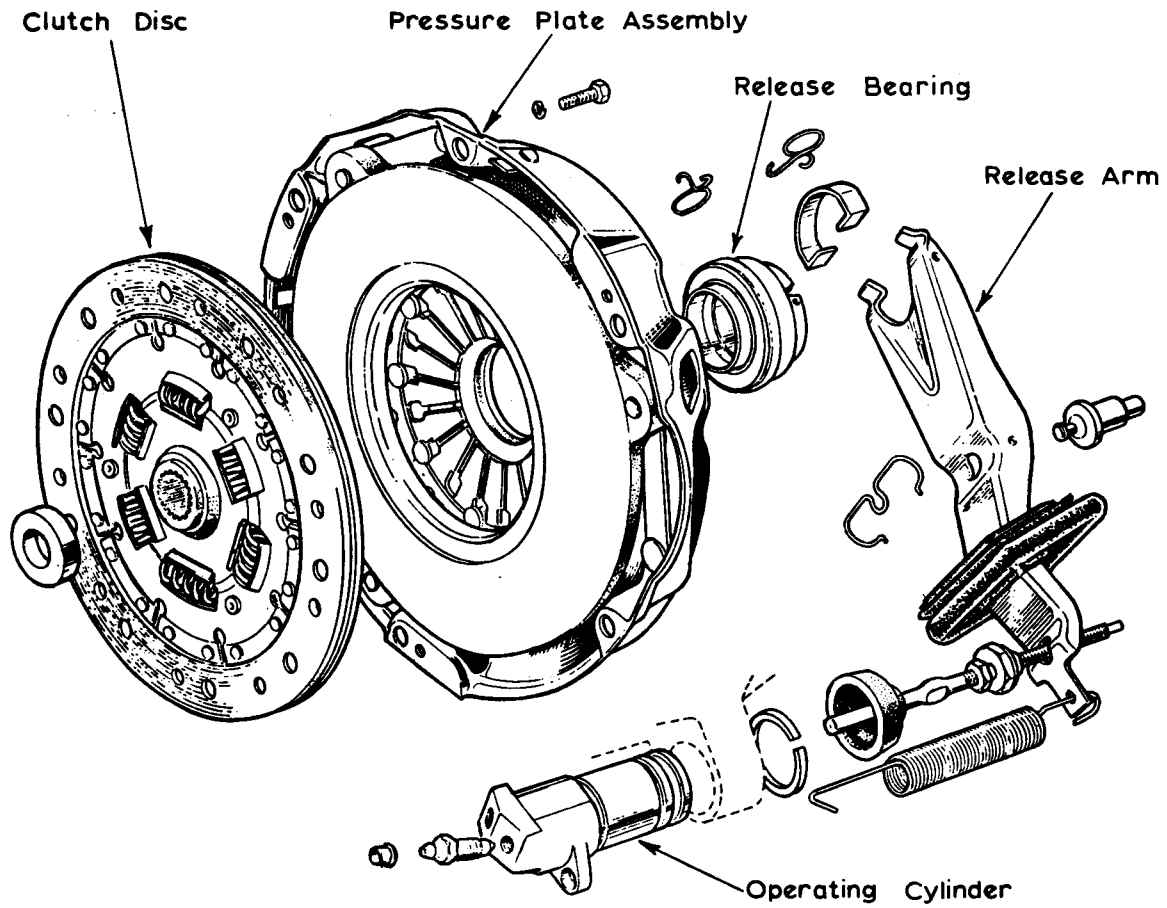

TD-50-Q1

Fig. 1. CLUTCH COMPONENTS

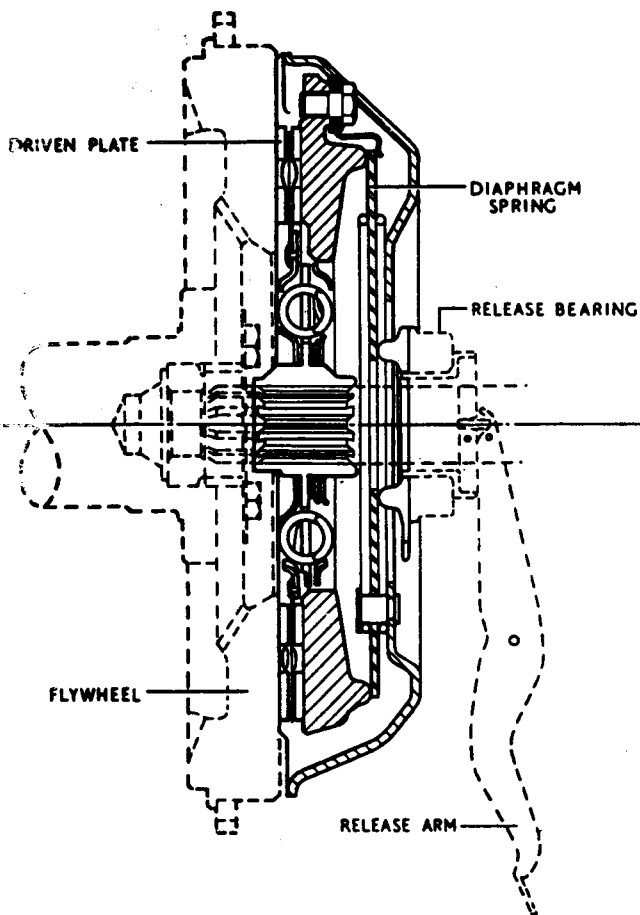

Fig. 2a. CLUTCH ENGAGED

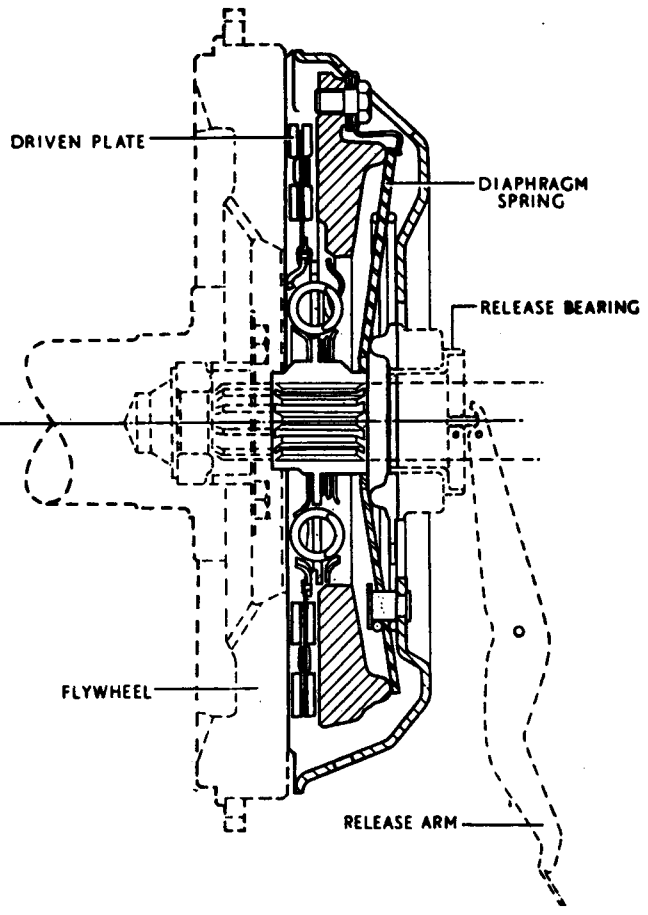

Fig. 2b. CLUTCH DIS-ENGAGED

Tighten the locknut securely, re-check the adjustment and reconnect the retracting spring.

Master Cylinder Topping-up

The clutch master cylinder is located at the rear end of the engine compartment, on the driving side.

Check fluid level in the reservoir at intervals of every 3,000 miles (5,000 km.), topping-up if necessary to within $\frac{1}{2}$ in. (12 mm.) of the top. Use only the specified fluid (see Section 'O') for topping-up.

Q.3. - CLUTCH ASSEMBLY

To Remove

1. Remove the engine (see Section 'E').
2. Remove the clutch assembly from the flywheel by progressively releasing the six bolts around the periphery of the assembly. Pull off the assembly from the locating dowels.

To Refit

1. Locate the driven plate on the flywheel using a dummy mainshaft.
2. Replace the clutch assembly on the flywheel by first ensuring it is located by the dowels, then insert the bolts and tighten to the torque loading given in 'Technical Data'. Remove the dummy mainshaft.
3. Before refitting the engine the opportunity should be taken to lubricate the clutch release bearing carrier (Fig.6) and the clutch fork pivot. Use Duckhams 'KE.24' grease or its equivalent.

Q.4. - CLUTCH DRIVEN PLATE

To Remove

1. Remove the clutch assembly (Section Q.3).

Inspection for Wear

Check the condition of the pressure plate surface and should it show any signs of distortion, scoring or overheating it is recommended that it be replaced by a new assembly. It is essential to install a complete driven plate assembly when renewal of pressure plate is required. If the facings have worn to such an extent as to warrant renewal, then slight wear will have taken place on the splines and also on the torque reaction springs and their seatings. The question of balance and concentricity is also involved. Under no circumstances is it satisfactory to repair or rectify faults in clutch driven plate centres, and

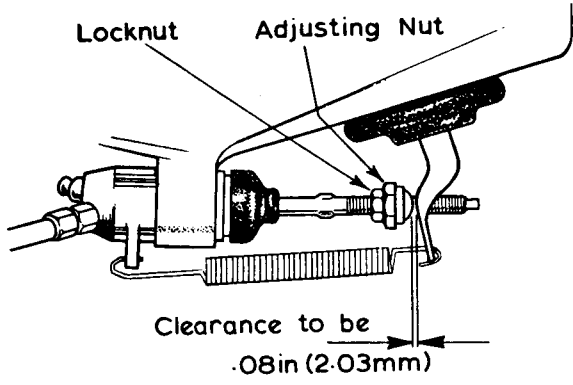

Fig. 3. CLEARANCE AT RELEASE ARM *TD-50-03*

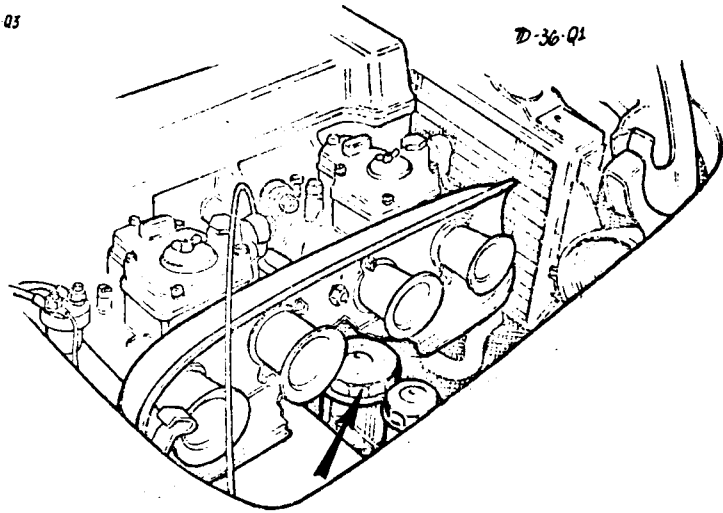
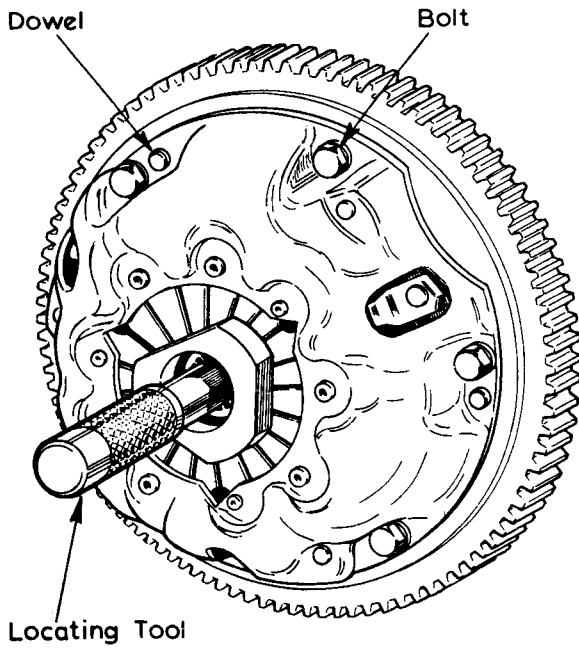

Fig. 4. CLUTCH FLUID RESERVOIR



TD-50-05

Fig. 5. CLUTCH DISC LOCATION

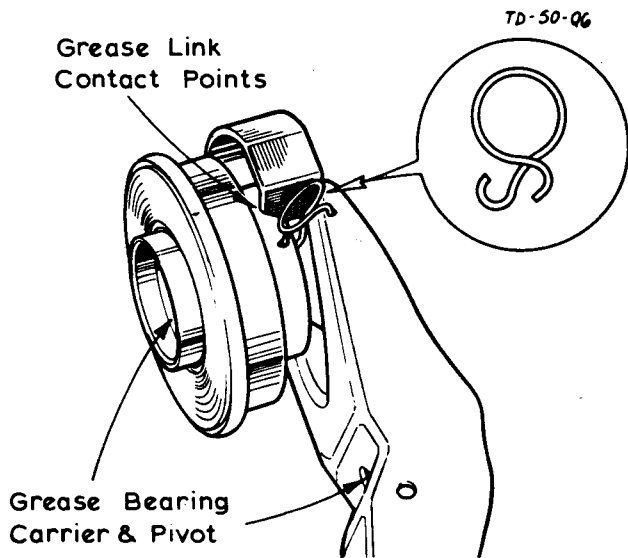

Fig. 6. THRUST BEARING LINKAGE TO ARM

we do not recommend this as manufacturers.

If the clutch has been in use for some time under satisfactory conditions, the surface of the facings assumes a high polish through which the grain of the material can be seen clearly. The polished facing is of light colour when in perfect condition.

Should oil in small quantities gain access to the clutch and find its way on to the facings, it will be burnt off as a result of heat generated by the slipping occurring under normal starting conditions. The burning of this small quantity of lubricant has the effect of gradually darkening the facings, but provided the polish of the facings remain such that the grain of the material can be distinguished clearly, it has little effect on the clutch performance.

Should increased quantities of oil reach the facings then one or two conditions or a combination of these, may arise, depending upon the nature of the oil.

- a. The oil may burn off and leave a carbon deposit on the surface of the facings, which assume a high glaze, producing further slip. This is a very definite, though very thin, deposit, and in general it hides the grain of the material.
- b. The oil may partially burn and leave a resinous deposit on the facings. This has a tendency to produce a fierce clutch, and may also cause excessive spinning, due to the tendency of the face of the linings to adhere to the surface of the flywheel or pressure plate.
- c. There may be a combination of conditions 'a' and 'b' which produces a tendency to 'judder' on such engagement.

Still greater quantities of oil produce a dark and soaked appearance of the facings, and the result will be further slip, accompanied by fierceness or 'juddering'.

If the conditions enumerated above are experienced, the clutch driven plate should be replaced by a new one. The cause of the presence of oil must be traced and removed. It is of course, necessary for the clutch and flywheel to be cleaned thoroughly before assembly.

To Replace

1. Replace the clutch assembly. (Section 'Q.3').

Q.5. - RELEASE BEARING

To Remove

1. Remove the clutch assembly. (Section 'Q.3.').
2. Disconnect the pull off spring on the slave cylinder, remove the rubber gaiter from

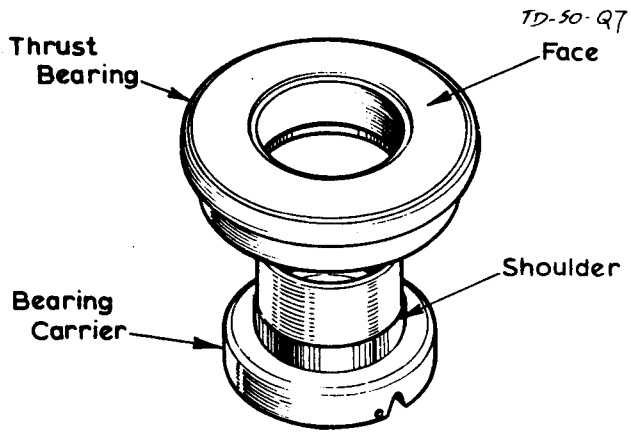
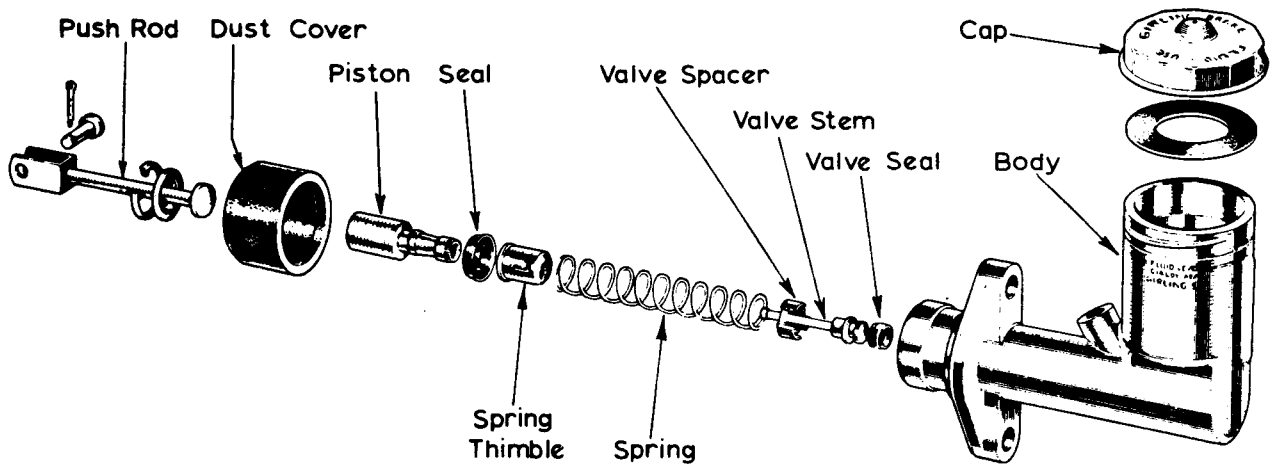

Fig. 7. FITTING CLUTCH THRUST BEARING TO CARRIER



TD-50-Q8

Fig. 8. MASTER CYLINDER COMPONENTS

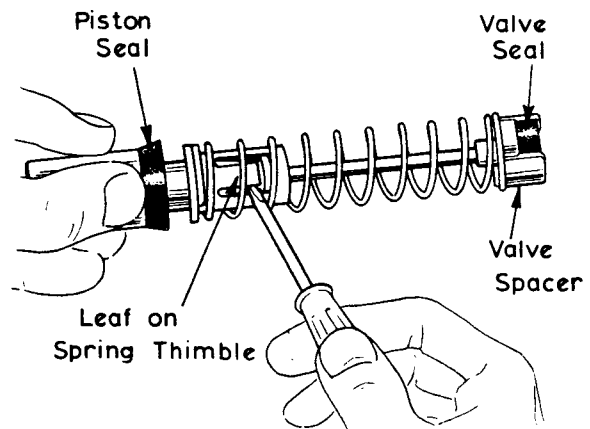

Fig. 9. DISMANTLING SEALS TD-50-Q9

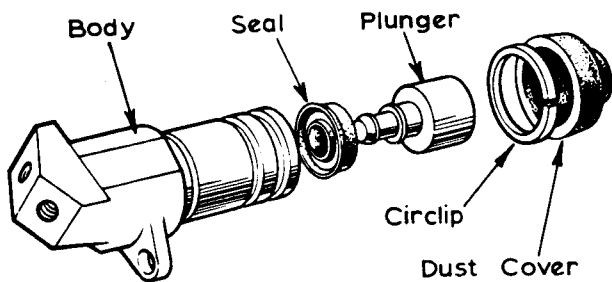

Fig. 10. SLAVE CYLINDER TD-50-Q10

the arm and clutch housing, noting carefully the way it is assembled. Remove the two springs from the clutch fork. Remove the clutch bearing with the bearing retainer, remove release fork bearing-link and the release arm by withdrawing into the clutch housing.

Removing the Bearing

1. Hold the release bearing and hub, with the bearing facing downwards.
2. Tap the hub sharply on a block of wood, whereupon the bearing will part from its hub.

Re-assembling the Bearing

1. Fit the bearing on to the hub, with its thrust face away from the hub shoulder. Using a suitable press, press the bearing squarely onto the hub shoulder.

To Replace

1. Replacement is a reversal of the removal procedure, not forgetting to lubricate the release bearing and the clutch fork pivot as detailed in Section 'Q.3'.

Q.6. - HYDRAULIC SYSTEM

To Bleed

1. Attach a tube to the bleed screw on the slave cylinder. The free end of the tube should be immersed in clean recommended fluid (see Section 'O'), which is contained in a clean glass jar.
2. Fill the master cylinder reservoir with recommended fluid, then open the bleed screw $\frac{3}{4}$ of a turn.
3. Using slow, full strokes, pump the clutch pedal until the fluid entering the container is completely free of air bubbles. The master cylinder should be kept topped-up during this operation, otherwise more air will be drawn into the system.
4. On a downward stroke of the pedal, tighten the bleed screw and remove the bleed tube. Check the pedal operation and, if not satisfactory, repeat the bleeding operation.

Q.7. - MASTER CYLINDER

To Remove

1. Disconnect the hydraulic fluid pipe from the clutch master cylinder. Fit a plug into the end of the pipe to avoid the ingress of foreign matter and the unnecessary wastage of hydraulic fluid.
2. Remove the split pin and withdraw clevis pin securing the master cylinder push rod to the clutch pedal. Remove nuts and bolts retaining master cylinder to foot well.

Dismantling

Remove the retaining circlip with a pair of long-nosed pliers and extract the dished washer and push rod. When the push rod has been removed the plunger with seals attached will be exposed; remove the plunger assembly complete. The assembly can be separated by lifting the thimble leaf over the shouldered end of the plunger. Depress the plunger return spring allowing the valve stem to slide through the elongated hole in the thimble, thus releasing the tension on the spring. Remove the thimble, spring and valve complete. Detach the valve spacer, taking care of the spacer spring washer which is located under the valve head, and remove the seal from the valve head.

Examine all parts for wear or distortion and fit new parts where necessary, including all seals which are contained in the appropriate service kit (see Service Parts List).

Re-assembly

Replace the valve seal so that the flat side is correctly seated on the valve head. The spring washer should then be located with the domed side against the underside of the valve head, and held in position by the valve spacer, the legs of which face towards the valve seal. Replace the plunger return spring and depress until the valve stem engages through the elongated hole of the thimble, ensuring that the stem is correctly located in the centre of the thimble. Check that the spring is still central on the spacer. Fit a new plunger seal with the flat face of the seal against the face of the plunger. Fit a new plunger end seal.

Insert the smaller end of the plunger into the thimble until the thimble leaf engages under the shoulder of the plunger. Press home the thimble leaf. Insert the plunger assembly into the cylinder bore valve end first, carefully easing the plunger seal lips into the cylinder followed by the push rod, washer and circlip, which engages in the groove machined in the cylinder body.

To Replace

1. Refit the clutch master cylinder to the foot well.
2. Reconnect the hydraulic fluid pipe, after removing the dirt excluding plug, to the clutch master cylinder.
3. Finally, bleed the clutch (Section 'Q.6') hydraulic system.

Q.8. - SLAVE CYLINDER

To Remove

1. Disconnect the retracting spring, then remove the circlip which secures the slave cylinder into the lug on the clutch housing.