

SECTION R

FINAL DRIVE

<u>Section</u>	<u>Description</u>	<u>Page</u>
R.1	Differential - general description	3
R.2	Differential - remove and replace	3
R.3	Differential - overhaul	5
R.4	Propeller shaft	15
R.5	Intermediate drive shaft	19
R.6	Rotoflex couplings	19
-	Outboard drive shafts (see Section 'G').	
-	Hubs (see Section 'G').	
	<u>Additional Information</u>	
R.7	Differential unit replace ('Sprint')	21

ILLUSTRATIONS

<u>Fig. No.</u>	<u>Description</u>	<u>Page</u>
1.	Final drive arrangement	4.
2.	Filler/level plug	4.
3.	Washer sequence	4.
4.	Differential unit components	6.
5.	Bearing cap markings	8.
6.	Planet gears and carrier	8.
7.	Spider shaft location	8.
8.	Setting depth gauge	10.
9.	Measuring pinion mesh	10.
10.	Assembling pinion	10.
11.	Measuring backlash	12.
12.	Correct tooth contact	12.
13.	Incorrect tooth contact	14.
14.	Sliding splines & front universal	16.
15.	Propeller shaft components	16.
16.	Removing bearings	18.
17.	Tapping out bearings	18.
18.	Fitting gaskets	18.
19.	Intermediate drive shaft & Rotoflex coupling	20.
20.	Coupling bolts	20.

## DIFFERENTIAL

### R.1. - GENERAL DESCRIPTION

The differential unit is flexibly mounted at both its upper and lower securing points. The crown wheel and pinion are mounted in the differential carrier, which is bolted to the front face of the differential casing.

Adjustments are provided for pinion bearing pre-load, crown wheel and pinion backlash and pinion depth of mesh.

#### Lubrication

The combined filler/level plug is located in the rear of the housing, and the drain plug in the lower right front of the housing. When checking the oil level the car should be standing on level ground. Remove the level plug and check that the oil level is up to the bottom of the hole. If necessary, add oil (see Section 'O') to bring it to this level. Refit the level plug and tighten it securely.

### R.2. - DIFFERENTIAL UNIT

#### To Remove

1. Remove the rear wheels (see Section 'G').
2. From inside the forward end of boot (trunk), release the trim on top of the hump (see Section 'B').
3. Disconnect the left-hand lower wishbone (see Section 'D'). Remove the Rotoflex couplings (Section 'R.6').
4. Disconnect the propeller shaft from the differential driving flange. Disconnect the forward ends of the differential torque rods from their location on the chassis.
5. From inside the boot (trunk), remove the differential unit retaining bolt nuts which pass through the chassis rubber mountings.
6. From below the car, withdraw the differential unit from the left-hand side.

#### To Replace

1. Lift the differential unit into position from the left-hand side and adjust unit to give a clearance between the top of the unit and the chassis crossmember. This may necessitate the removal of one of the two washers on either or both sides. A minimum of one washer must be left between the top lugs of the differential unit and the chassis crossmember and between the head of the bolt and the rubber mountings. It is essential that the large 2 in. (5 cm.) diameter washers are used and not substituted by others, as they serve a twofold purpose in being both spacers

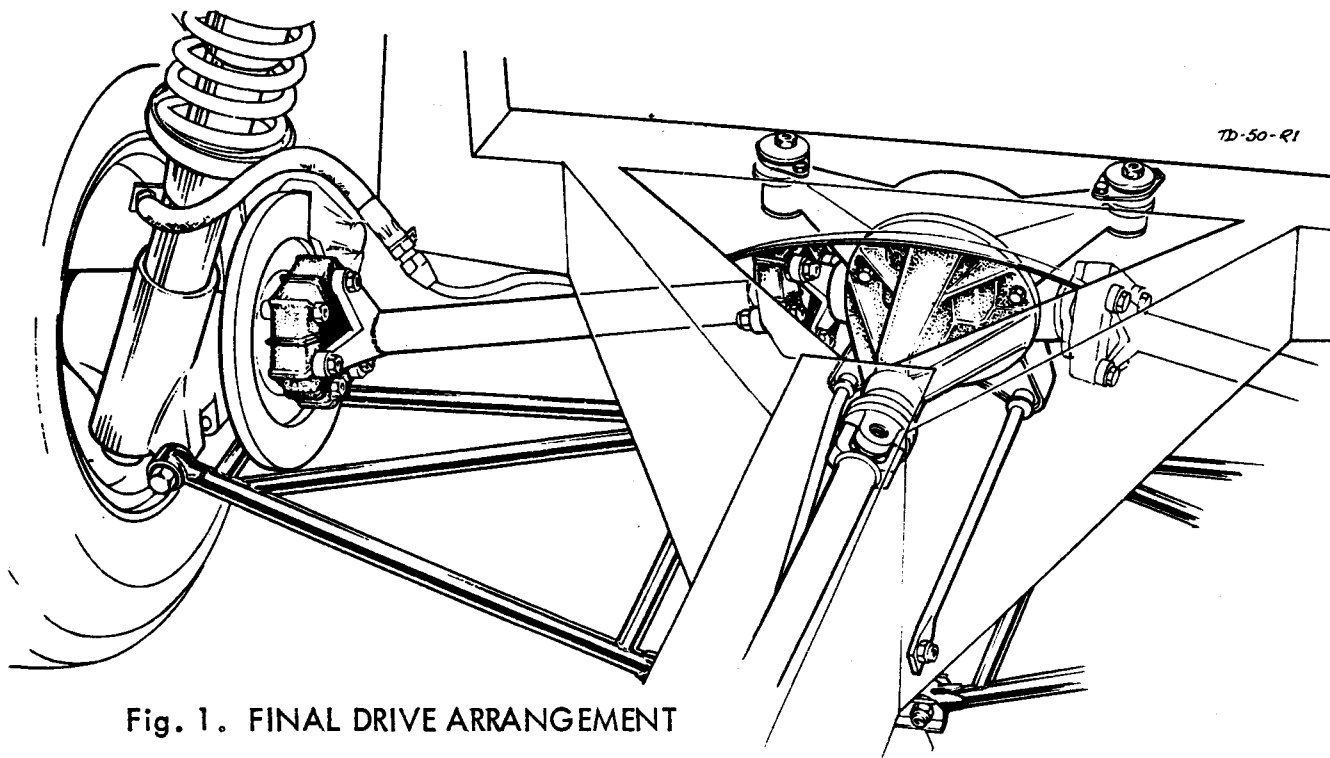

Fig. 1. FINAL DRIVE ARRANGEMENT

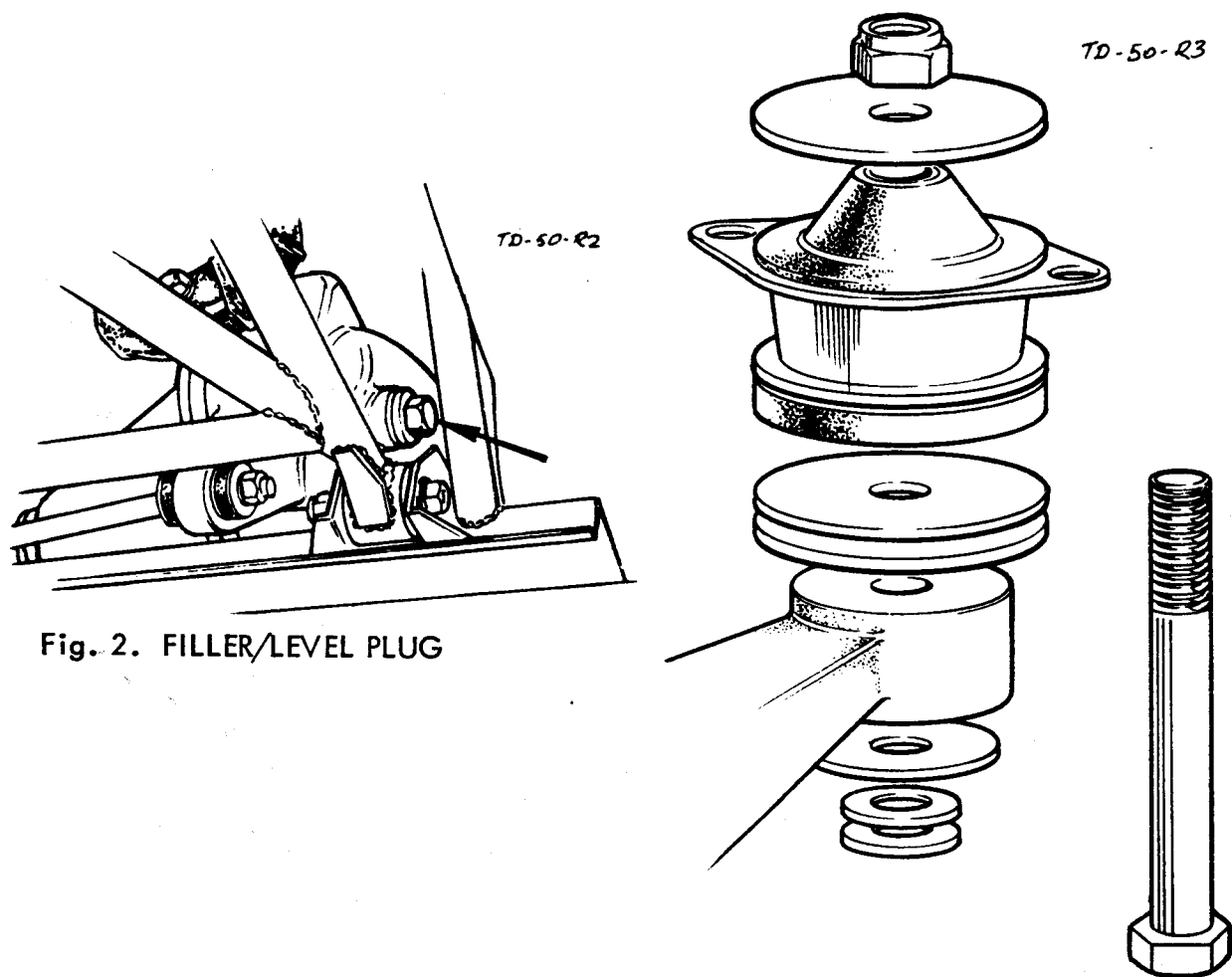

Fig. 2. FILLER/LEVEL PLUG

Fig. 3. WASHER SEQUENCE

and stopping the rubber bushes from spreading (see Section 'X'). Harder differential mounting rubbers (Part No. X036 R 6000Z) were introduced at Chassis No. 8930. New bolts (Part No. 50 R 027) which secure the differential to the mountings, together with two washers (Part No. 26 R 003) are now fitted between the differential and its mounting rubbers, this change being incorporated into current Production from Chassis No. 8930.

2. Attach the forward ends of the differential unit torque rods, following with the propeller shaft retaining nuts and bolts. Reconnect the left-hand wishbone, ensuring the spacer washers are located between the wishbone and the bearing housing. Note that the long bolt is fitted towards the front of the car. The torque rod rubbers (at the differential end) are assembled in the following sequence from the front :-

Rubber bush (next to fixed washer), cupwasher with large hole, differential unit lug, cupwasher with large hole, rubber bush, cupwasher with small hole, and finally the nut which should be torque loaded to the figure given in 'Technical Data'.

3. Attach the outer end of the drive shaft to its Rotoflex coupling, (see Section 'R.5' and 'R.6'), ensuring that the brake disc is running true within the caliper. Torque load the nuts to the figure given in 'Technical Data'.
4. Jack up the left-hand bearing housing from below the damper, to enable the inner end of the drive shaft to be attached to the other Rotoflex coupling (see Section 'R.5' and 'R.6'). It will be found easier to insert a bolt through the upper hole in the coupling and the lower hole in the driving flange, finger tightening the bolt. The other bolts can now be fitted by rotating the shaft around the one fixing bolt, inserting the bolts from the driving shaft side. Finally torque load all nuts to the figure given in 'Technical Data' and remove the coupling clamps.
5. Fit handbrake rod to caliper (see Section 'J').
6. Replace the trim in the boot (see Section 'B').
7. Refit road wheels. Finally, refill the differential with the specified oil (see Section 'O').

### R.3. - DIFFERENTIAL UNIT.

#### Overhaul

1. Remove the differential unit (Section 'R.2') to a clean bench. Drain the oil into



- a suitable receptacle .
2. Remove the circlip on either side of the outer bearing housing and gently tap out each drive shaft .
  3. Remove the bolts holding the differential carrier assembly to the differential casing and lift out the differential carrier assembly complete .
  4. Unscrew the bolts of the adjustment nut locking plate . Detach the plates . Note carefully that the bearing caps are marked for mating purposes and slacken the bearing adjustment nuts using a special creeper spanner (Tool No. P.4079) and detach the bearing caps after removing their bolts and lockwashers .
  5. The crown wheel assembly can now be carefully removed complete with bearings and adjustment nuts . (Note that each bearing should be kept with its corresponding cup). Unscrew the nut securing the drive pinion to the propeller shaft coupling flange, after carefully removing the staking from the flange . Withdraw the coupling flange from the pinion shaft . The pinion complete with its rear bearing assembly and spacer can now be withdrawn from the rear of the housing . Remove the pinion bearing cups and drive the front bearing and oil seals forwards out of the housing . Drive out the remaining rear pinion bearing cup from the front of the housing .
  6. To dismantle the pinion assembly it is first necessary to remove the spacer from the shaft in the following manner:
    - Place the unit on the bed of a suitable hand press .
    - Make sure that the bearing cage is not fouling, then press out the pinion .
  7. To dismantle the crown wheel and differential assembly, unscrew the lock bolts securing the crown wheel to the differential cage . Press the cage through the crown wheel . Drive out the taper pin situated in one end of the spider shaft away from the crown wheel side of the cage . Push the differential pinion shaft through the cage and extract the two pinions . Remove the conical thrust washers at the same time . Withdraw the two axle shafts gears and their thrust washers from the cage . Support the assembly on the bed of a hand press and press off the bearing cones taking care that the roller cage is not damaged in the process . Clean all components and inspect for wear or damage, replacing where necessary .
  8. Re-assembly is basically a reversal of the dismantling procedure . However, where new components have been included, it should be noted that all adjustments will

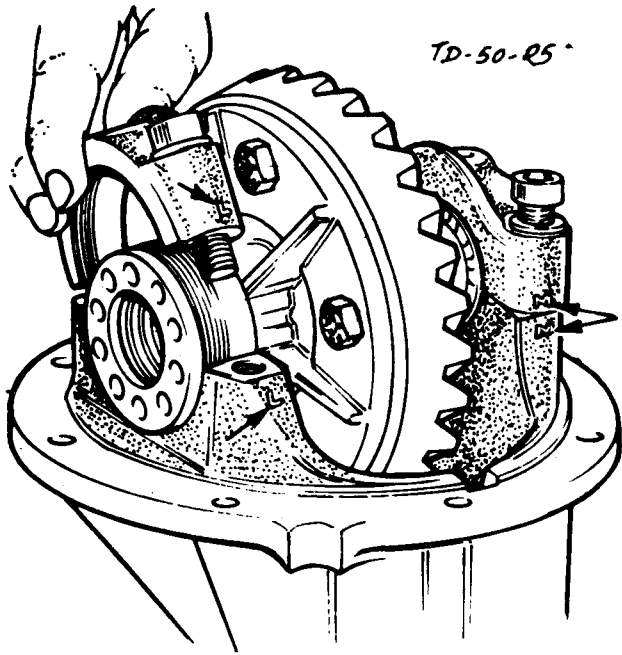

Fig. 5. BEARING CAP MARKINGS

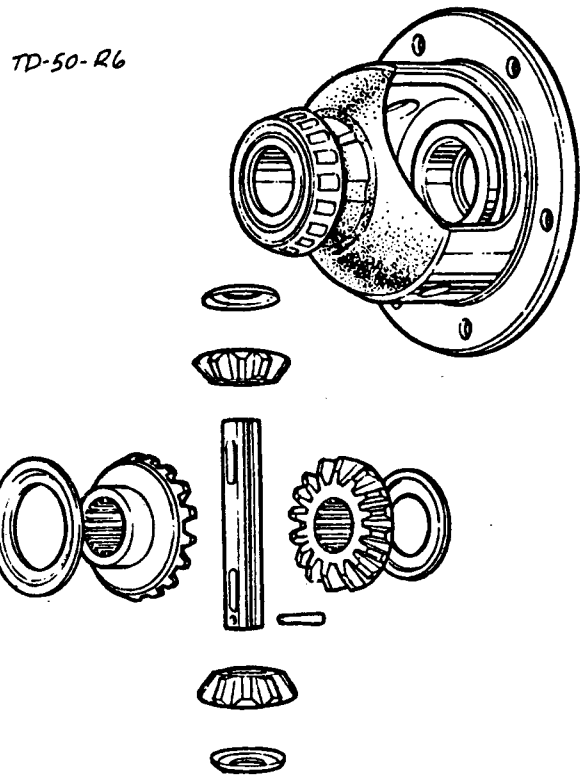

Fig. 6. PLANET GEARS & CARRIER

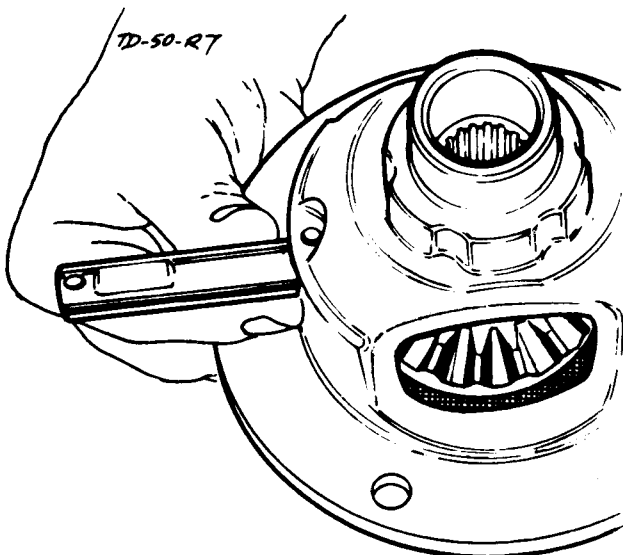

Fig. 7. SPIDER SHAFT LOCATION

- be affected. Care must therefore be exercised in re-assembly to obtain:
- a. the correct pinion bearing engagement by using the correct shim,
  - b. the correct pinion bearing preloading,
  - c. the correct crown wheel and pinion backlash and
  - d. the correct differential bearing preloading.
9. Lubricate the thrust washers and place them on the rear faces of the axle shaft gears. Insert the gears in the differential cage, then lubricate the conical thrust washers and locate behind each differential pinion. Place the pinions in the apertures of the cage diametrically opposite each other and rotate the axle shaft gears so that the hole for the spider shaft in the cage aligns the pinions.
  10. Insert the spider shaft after making sure that the taper pin hole will line up with its corresponding hole in the cage. Push the spider shaft home and insert the taper pin from the differential side of the cage. Drive the taper pin home and lightly peen over the cage.
  11. Locate the crown wheel on the cage and enter three bolts as pilot guides through the wheel and cage and press on using a suitable hand press and differential bearing cone. Remove the three bolts used as pilot guides and replace with six lock bolts tightening them to the torque loading given in 'Technical Data'. Press the differential driving cones into the cage.
  12. To fit the pinion bearing cups place the rear one on Tool No. P.4013-3 and insert through the carrier from the rear. Place the front bearing cup, followed by loose adaptor and wing nut to the centre bolt of the tool now protruding from the front of the carrier. Tighten the wing nut pressing both cups fully home. Unscrew the wing nut and remove the tool. To select the correct shim to control the pinion bearing engagement, the following procedure must be adhered to.
  13. Using Tool No. P. 4075-4 (in effect a driving pinion), slide the rear bearing onto its location, the larger diameter of the bearing being towards the pinion flange and fit the assembly to the differential carrier. Slide the front bearing cone with its smaller diameter inwards onto the tool and fit the drive shaft flange onto the pinion shaft splines. Fit the old pinion drive flange nut. Pre-load the pinion bearings by holding the drive flange with the Tool No. P.4028 and tighten the flange nut, whilst turning the pinion backwards and forwards to ensure the bearing rollers are seating correctly. Continue this operation until the rotation indicates that the bearings are correctly seated by an even bearing drag. Fit the pre-load gauge

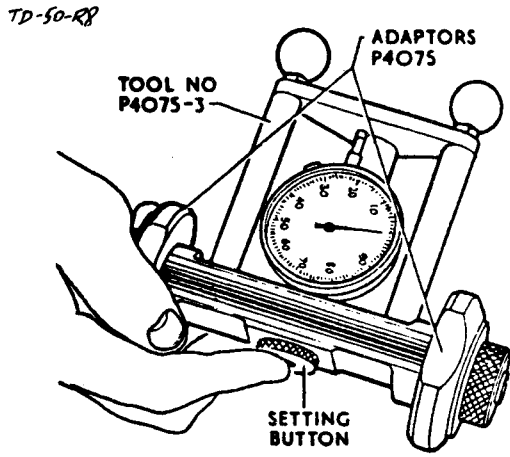

Fig. 8. SETTING DEPTH GAUGE

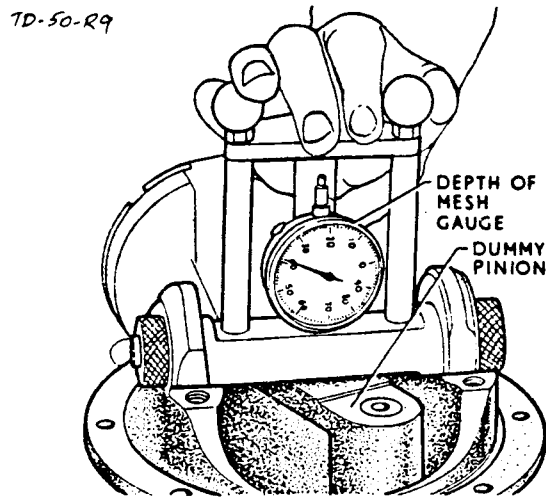

Fig. 9. MEASURING PINION MESH

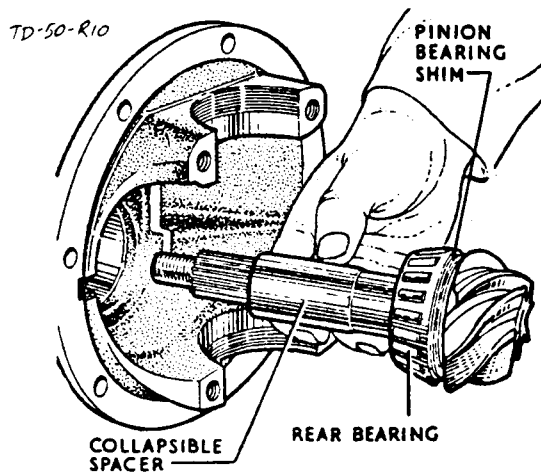

Fig. 10. ASSEMBLING PINION